



The Equinox Bridge

Keating Channel Pedestrian
Bridge

Presentation

September 2023



Land Acknowledgement

“Waterfront Toronto acknowledges that the land upon which we are undertaking our revitalization efforts, and where the designs in this procurement will be realized, is part of the traditional territory of the Mississaugas of the Credit First Nation and that Toronto is covered by Treaty 13 with the Mississaugas of the Credit First Nation (MCFN).

In addition, Waterfront Toronto acknowledges that Toronto has historically been a gathering place for many Indigenous people, including the Mississaugas of the Credit, the Anishinaabe, the Chippewa, the Haudenosaunee and the Wendat peoples, and is home to many First Nations, Inuit and Métis peoples today.”

From Design Brief



Team



Prime Proponent

WilkinsonEyre

Design Lead

ARUP

Engineering

PLANT

Plant



Indigenous Consultant/architect



Cost/QS



Dominic Bettison
WilkinsonEyre



Meighan King Wall
Two Row

Six Project Goals

Beautiful and Distinctive Gateway to the Waterfront



Connecting the City and Villiers Island

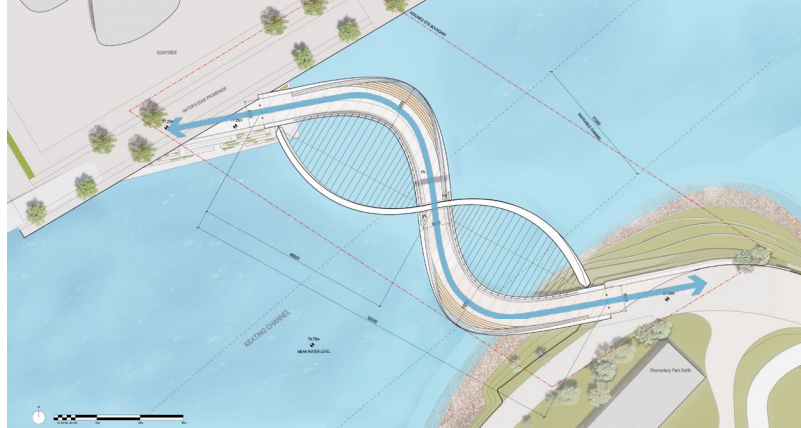

Incorporate a Living Landscape



Create with Indigenous Voice and Agency



Embody Sustainable Strategies and Innovation



Create a Place for All People



Site Analysis



Existing naturalised site condition along the south bank.



Existing site condition along the north bank with concrete slab.

Connectivity



Site Analysis

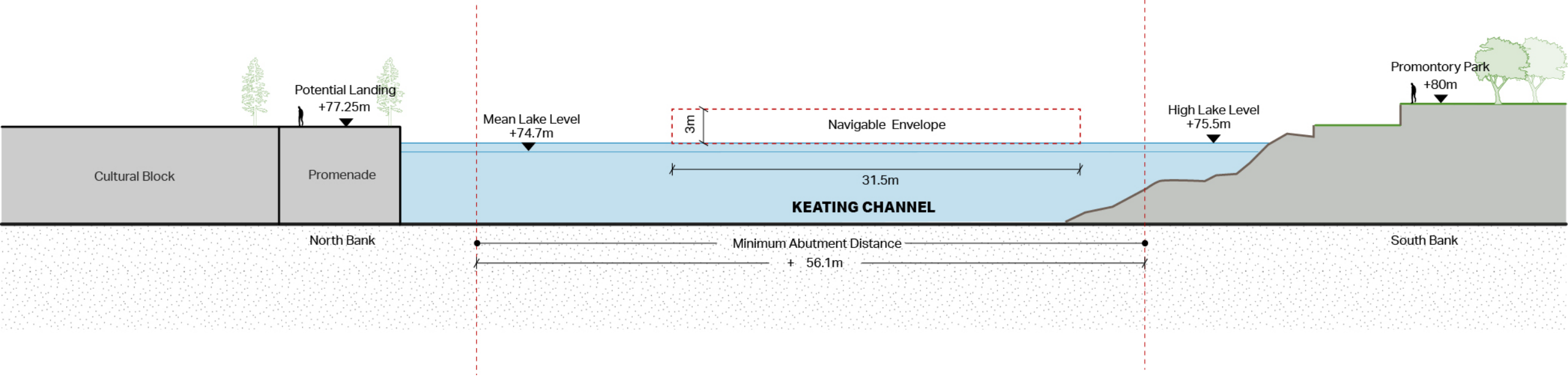

Section through Keating Channel with key site constraints

Site Analysis

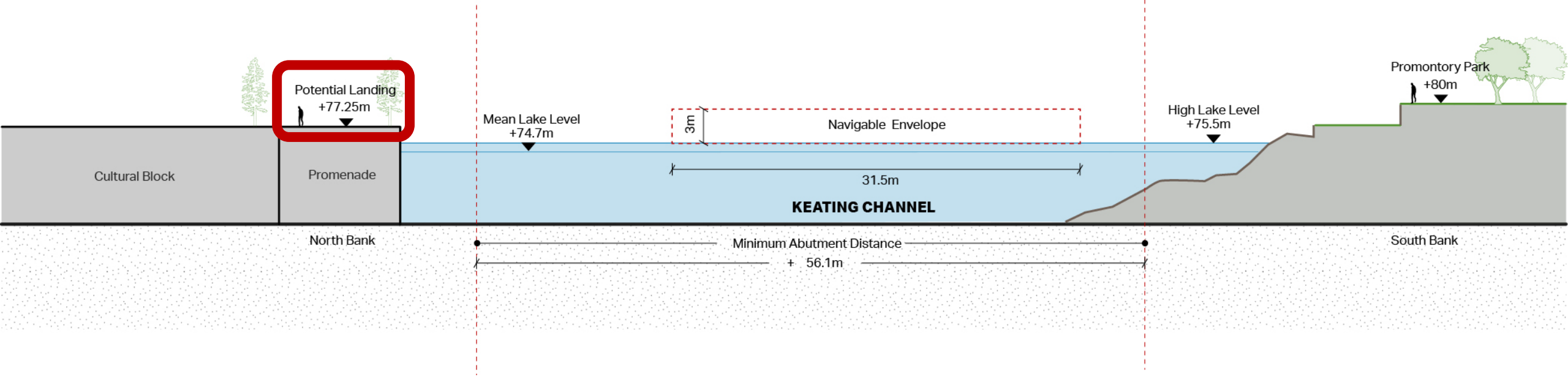

Section through Keating Channel with key site constraints

Site Analysis

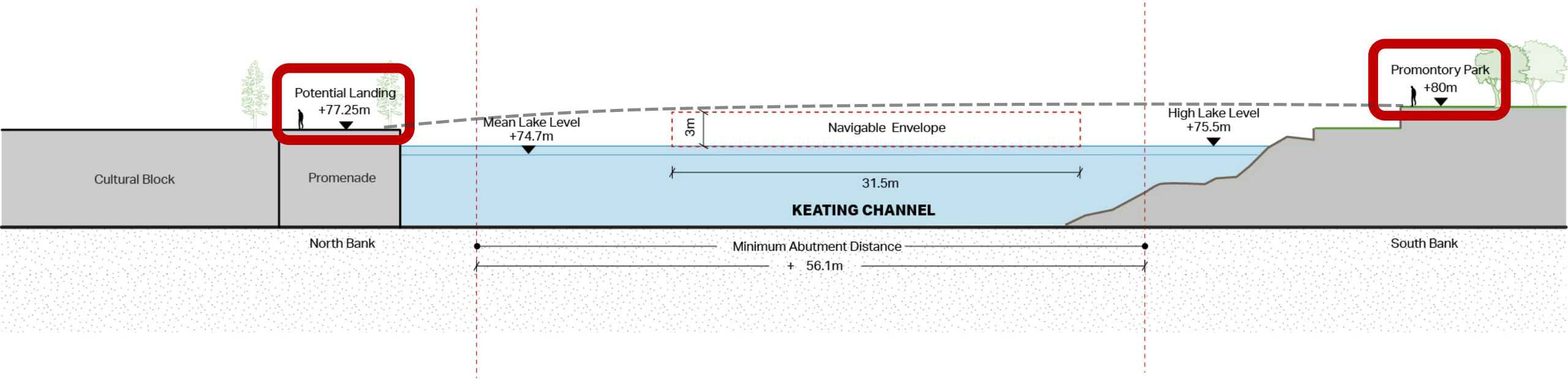

Section through Keating Channel with key site constraints

Concept Design Studies

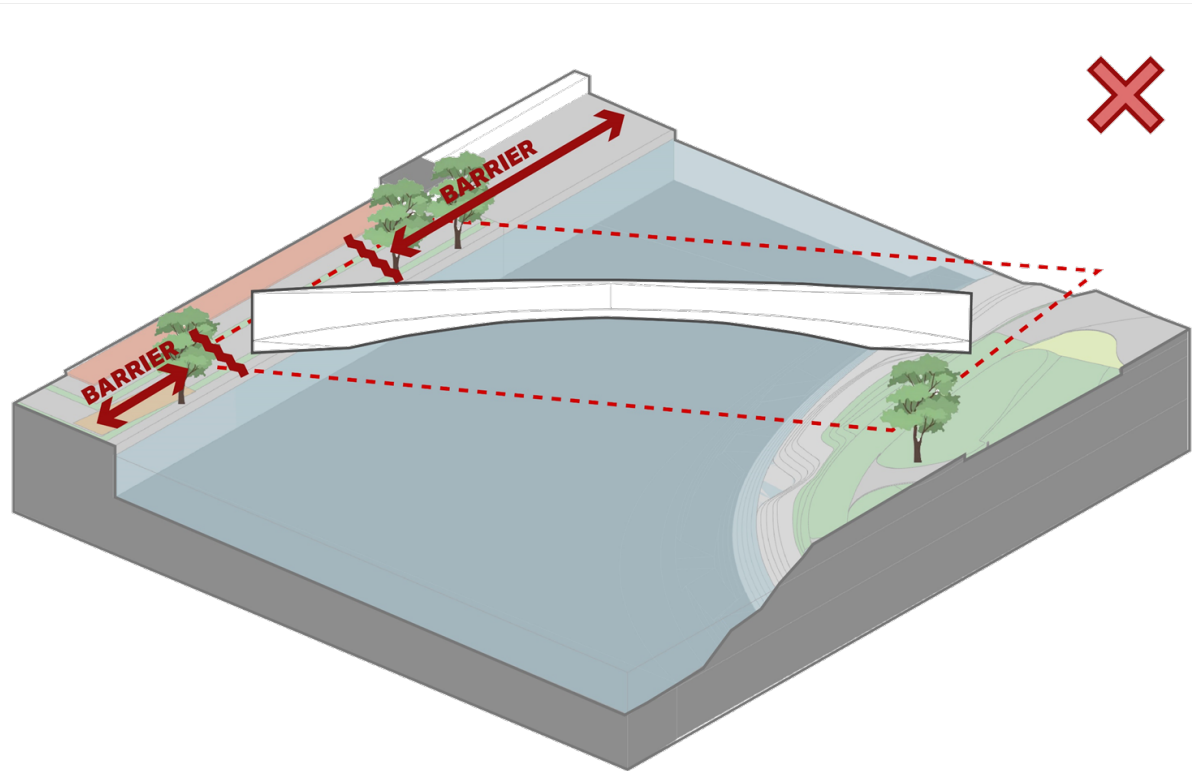

Straight Bridge with Ramped Deck

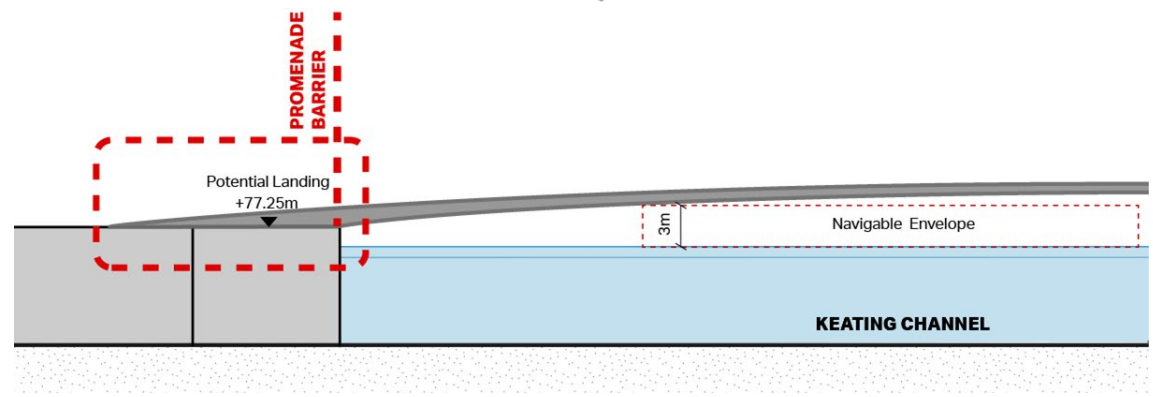

Concept Design Studies

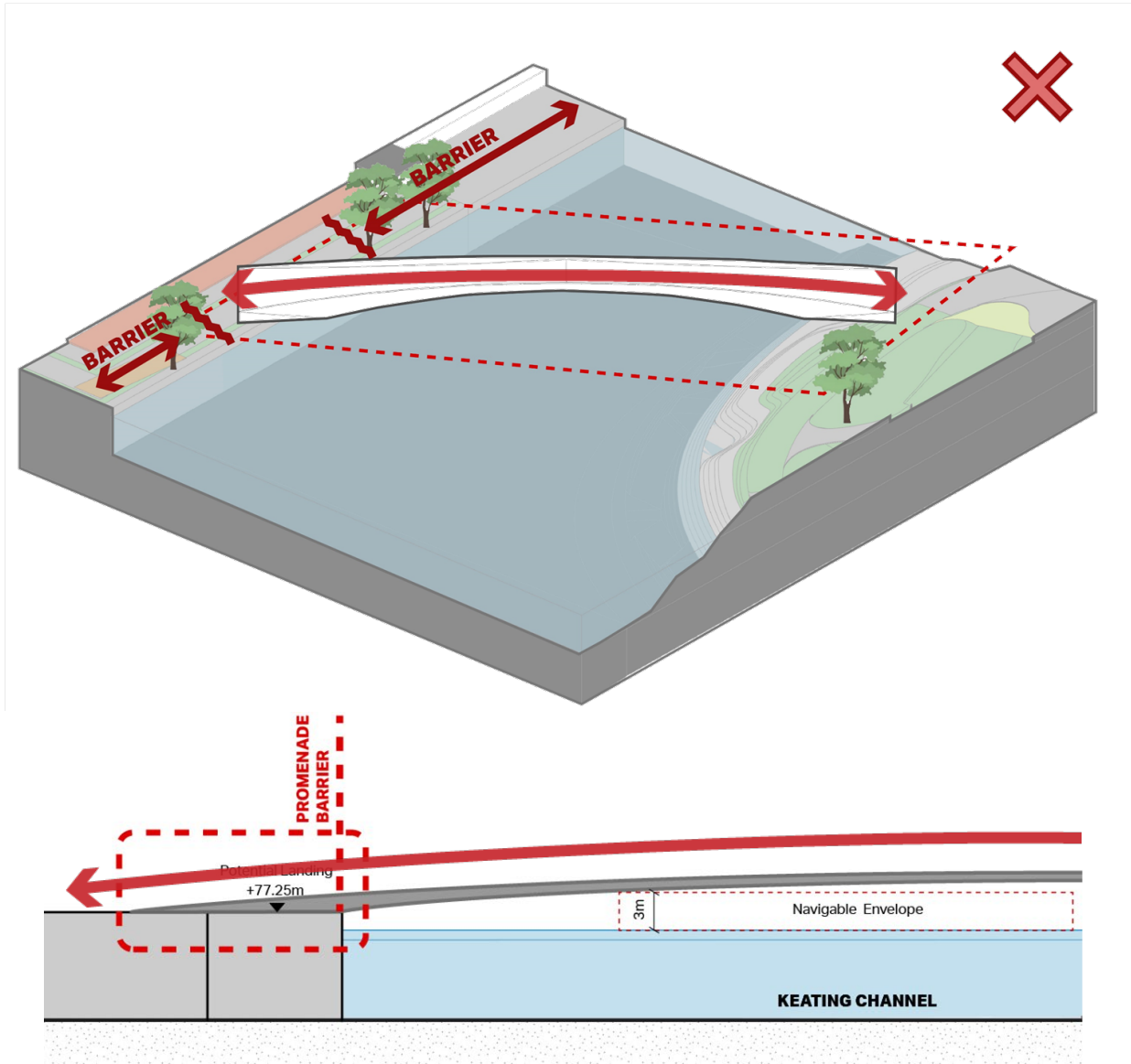

Straight Bridge with Ramped Deck

- Diagonal bridge alignment required to minimise impact on quayside
- Creates physical east-west barrier along quayside
- Significant ramp run off on quay edge to resolve levels

Concept Design Studies

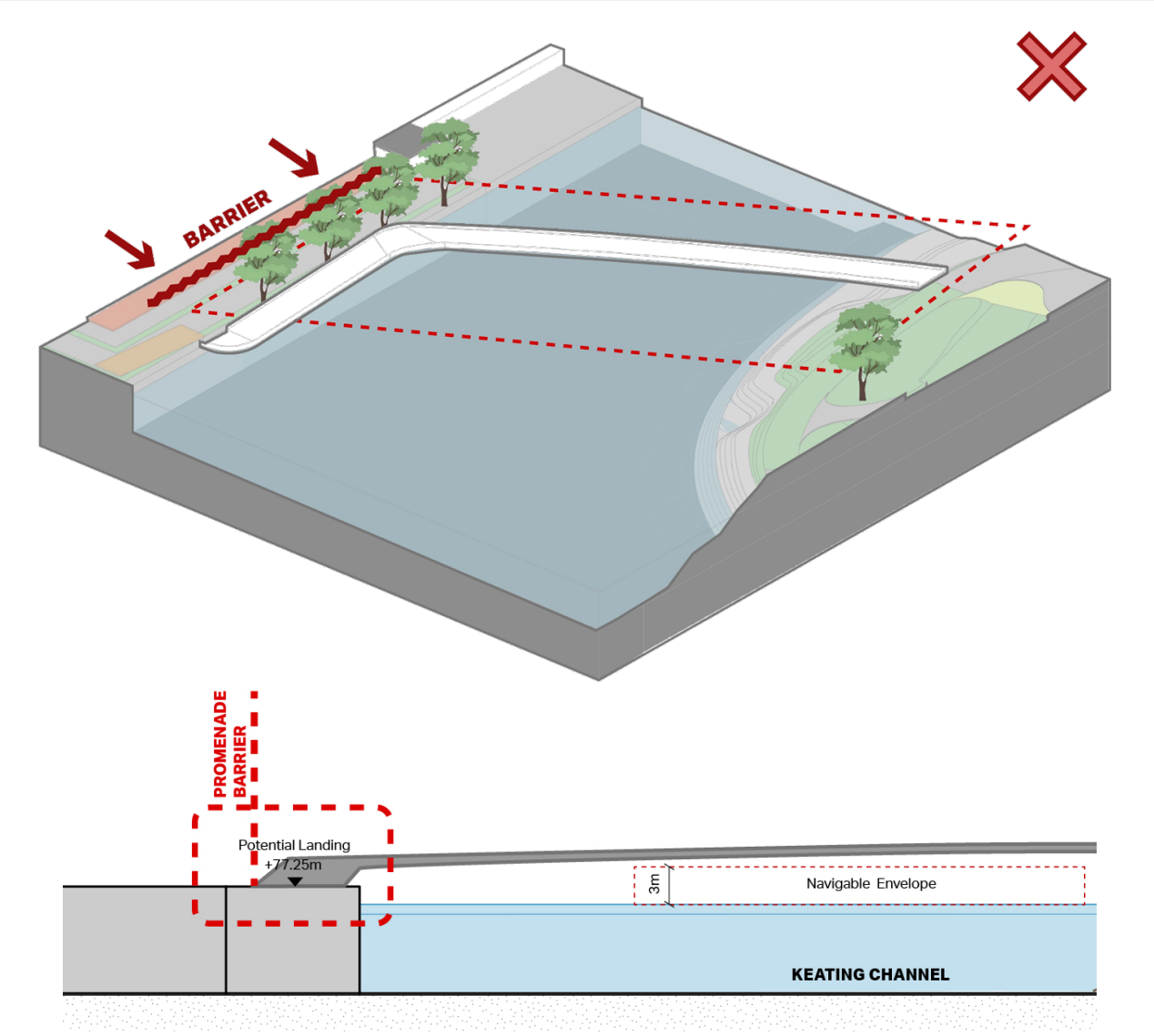

Straight Bridge with Ramping on Quayside

Concept Design Studies

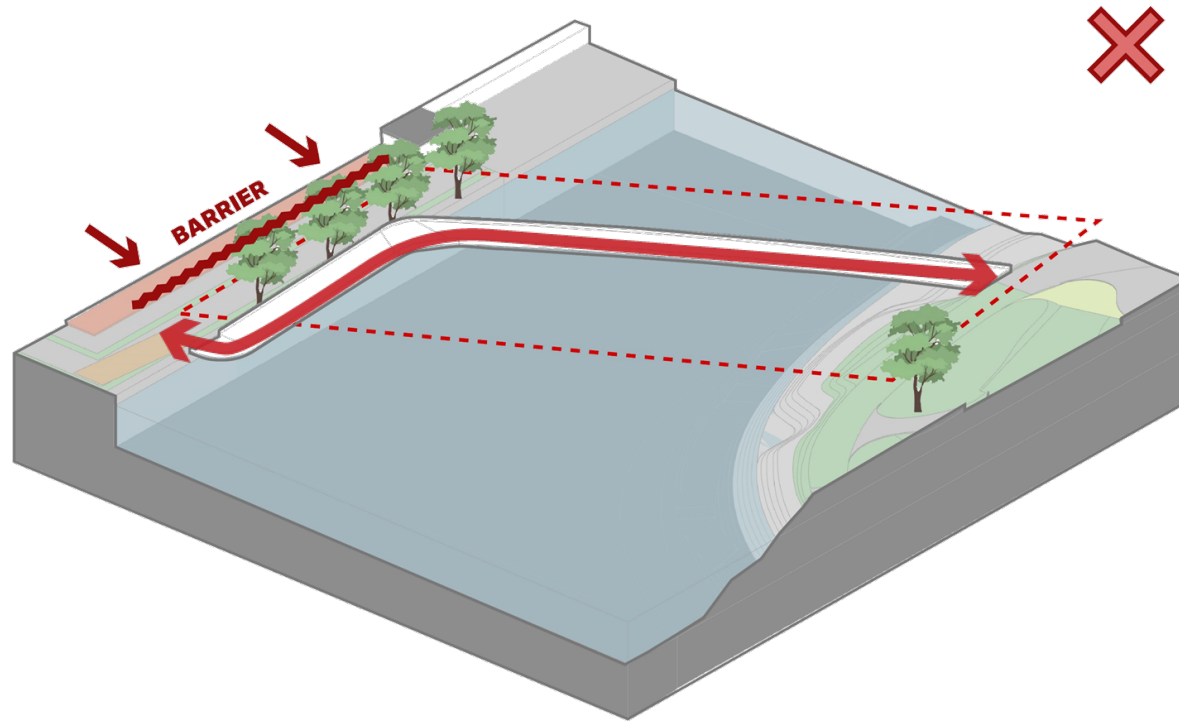

Straight Bridge with Ramping on Quayside

- + Bridge alignment less critical
- Creates physical north-south barrier to water along quayside
- Significant ramp run off parallel to quay edge to resolve levels

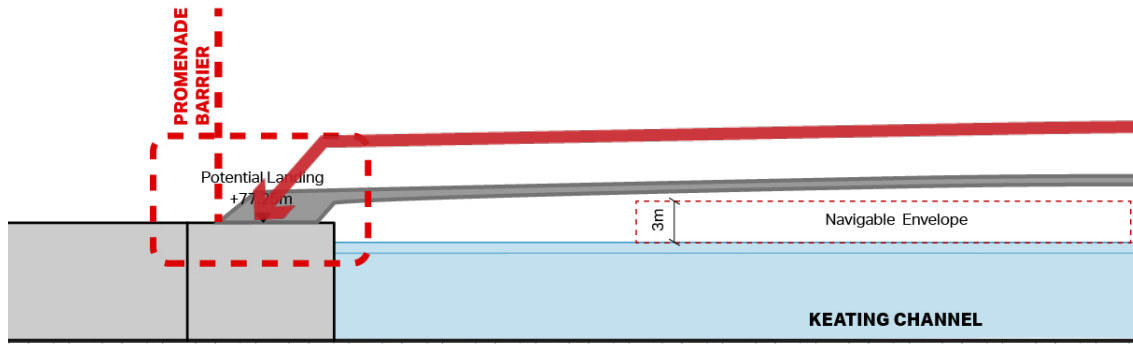

Concept Design Studies

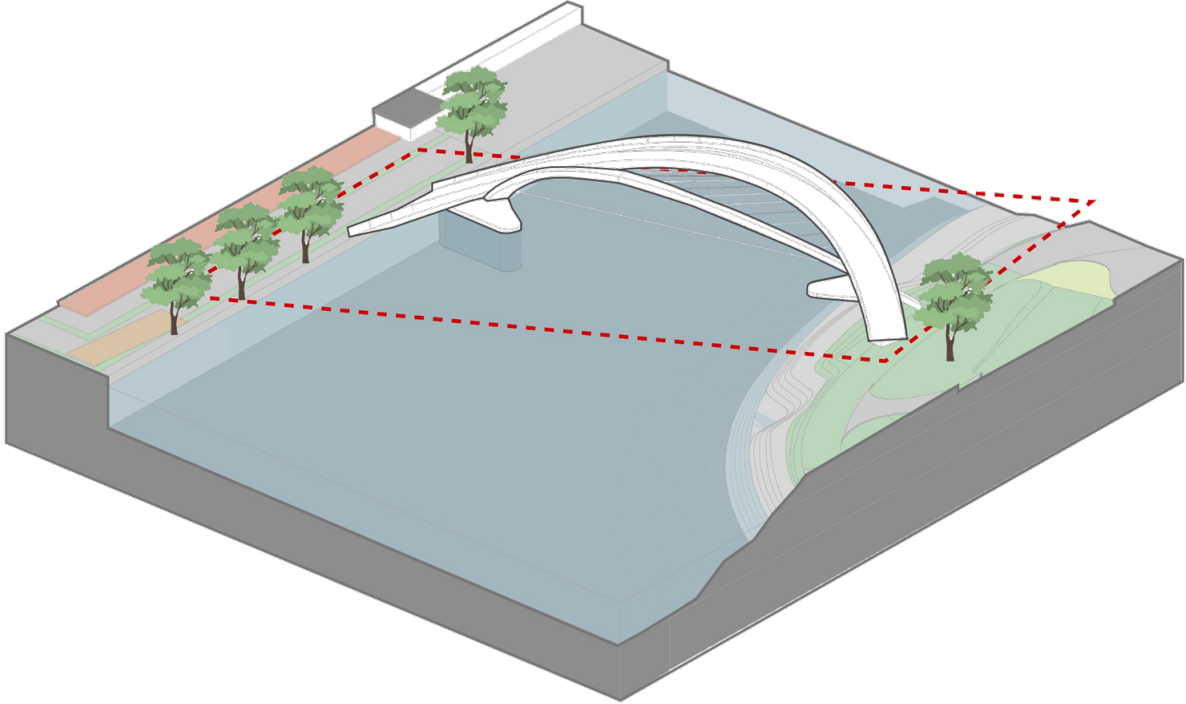

Curved Deck and Arch

Concept Design Studies

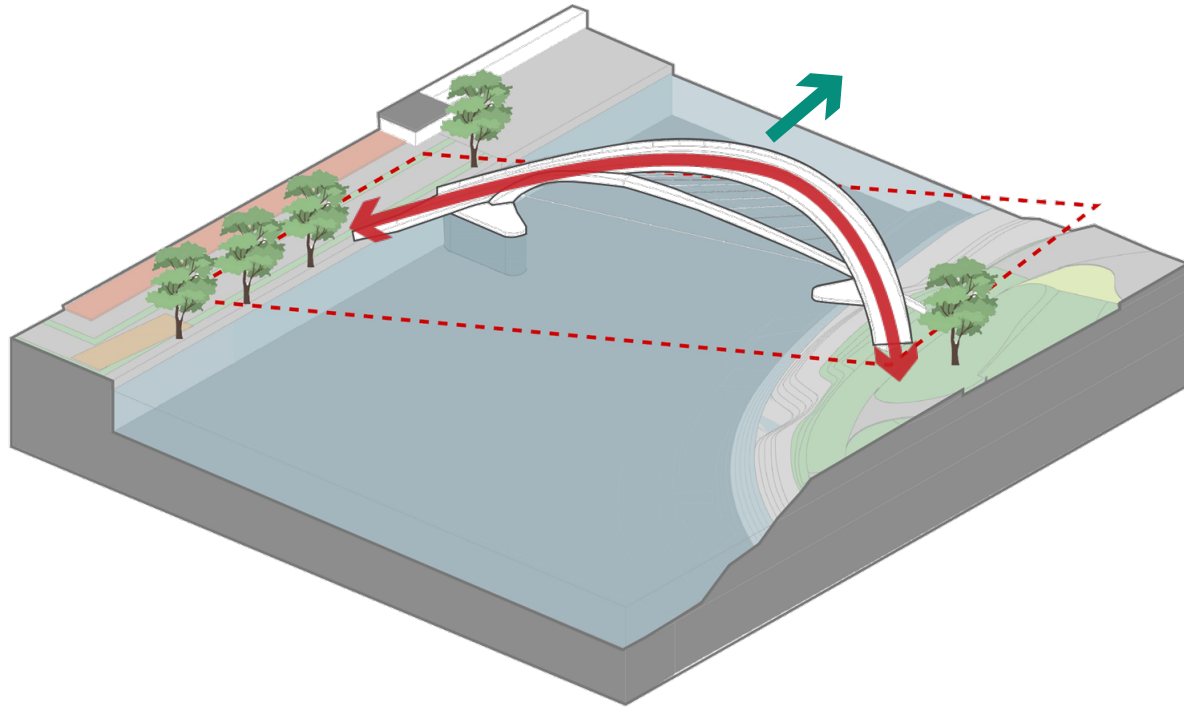

Curved Deck and Arch

- + No barriers at Quayside promenade
- + Curving deck length resolves levels at Quayside
- + Structurally efficient and cost effective to build
- Deck projects inland, views are not as good

Concept Design Studies

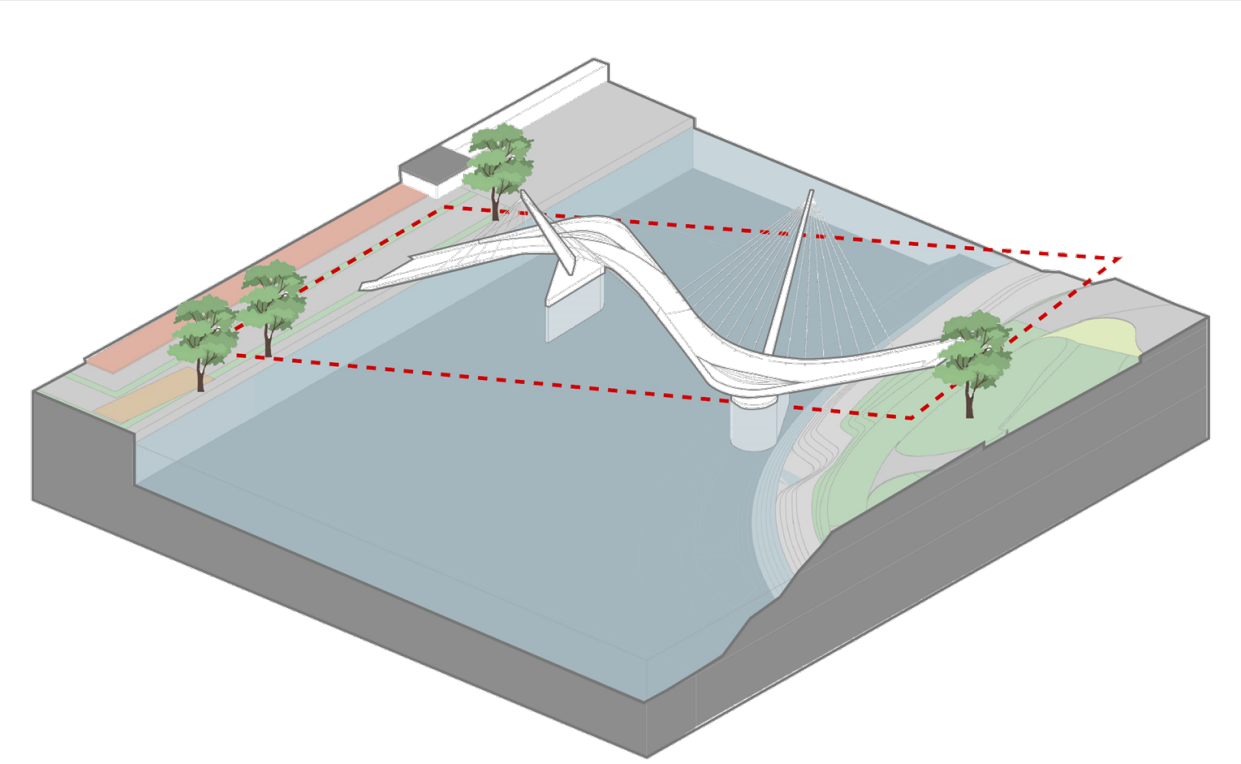

S-Deck and Masts

Concept Design Studies

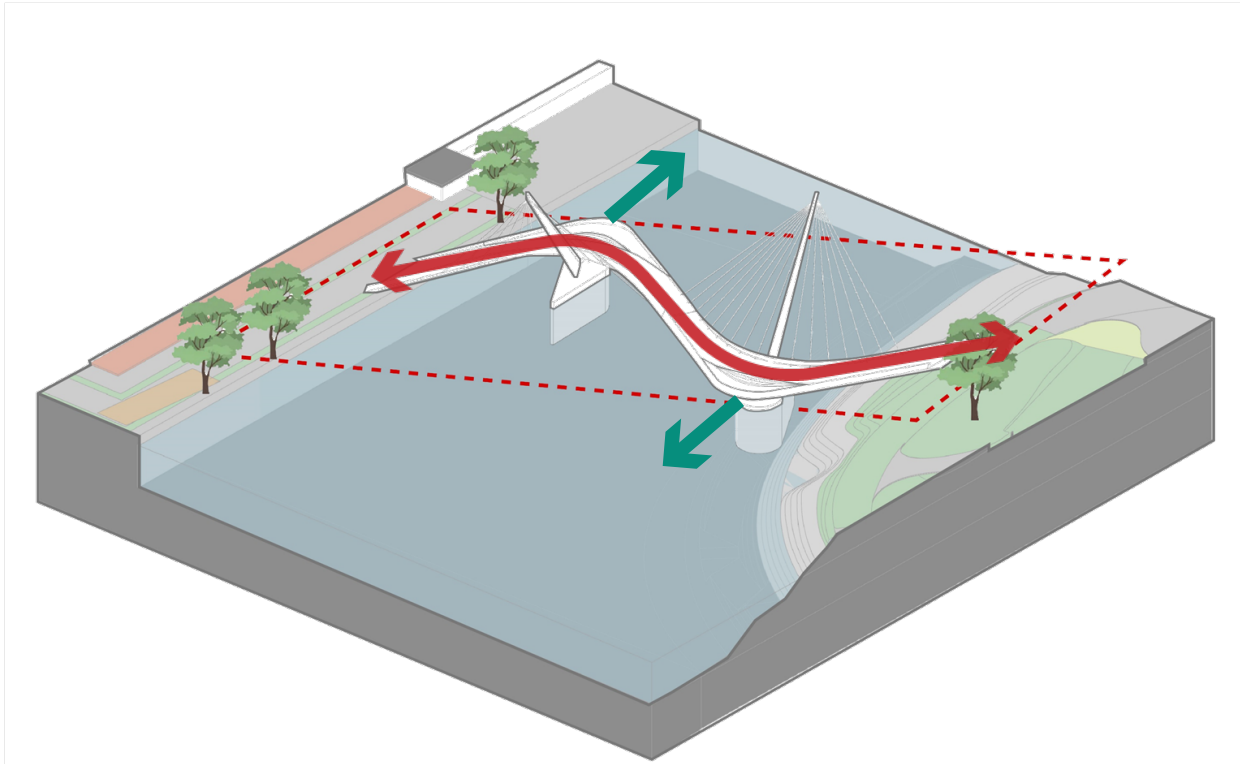

S-Deck and Masts

- + No barriers at Quayside promenade
- + Curving deck length resolves levels at Quayside
- + Natural traffic calming effect to allow pedestrians and cyclists to share bridge safely
- + Equal importance to each side of the bridge, creating a balanced approach and views to both sides
- + Informed by directionality and a connection to place
- Masts are structurally complicated and require piers in the water, more expense
- Doesn't tie in with the family of bridges

Concept Design Studies

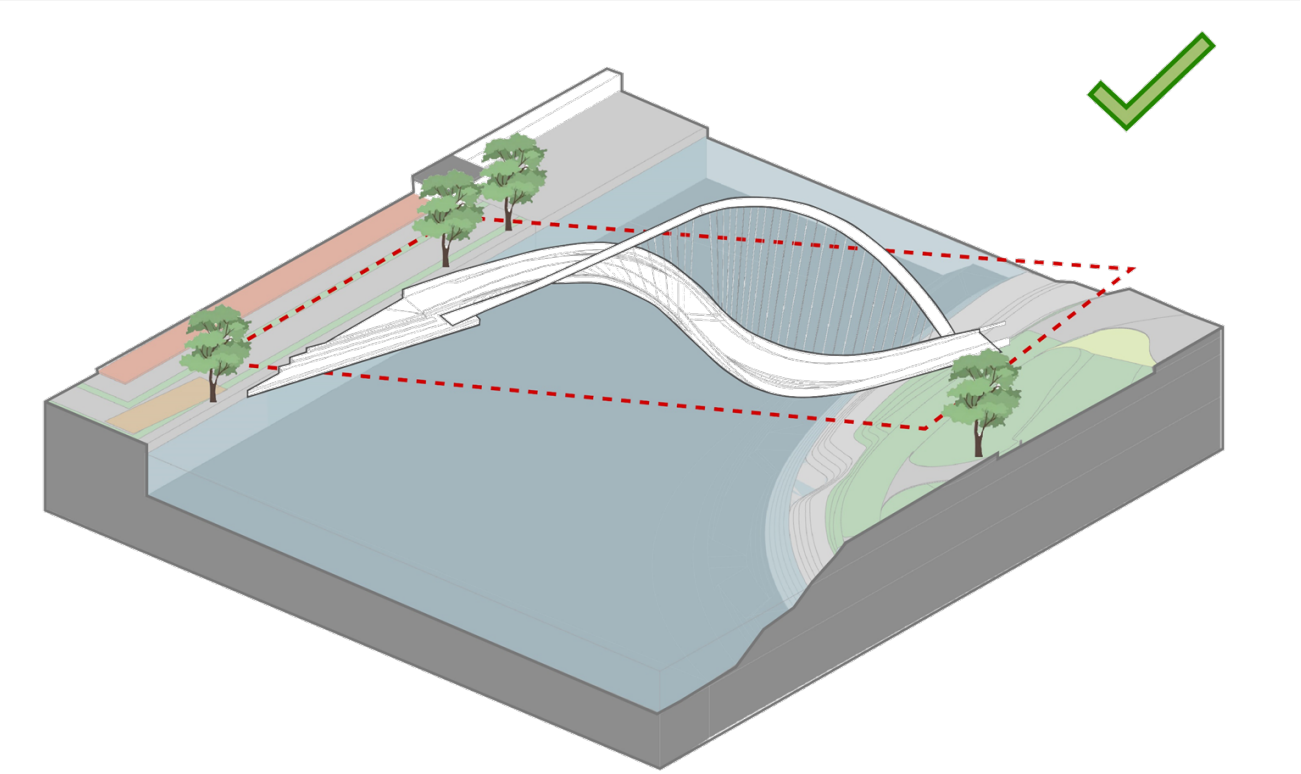

S-Deck and Arch

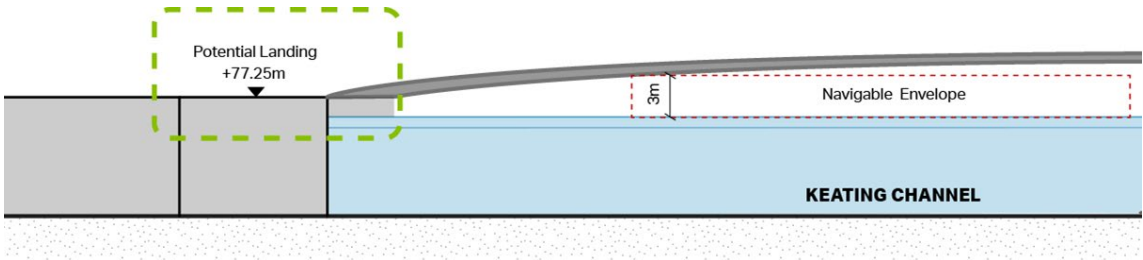

Concept Design Studies

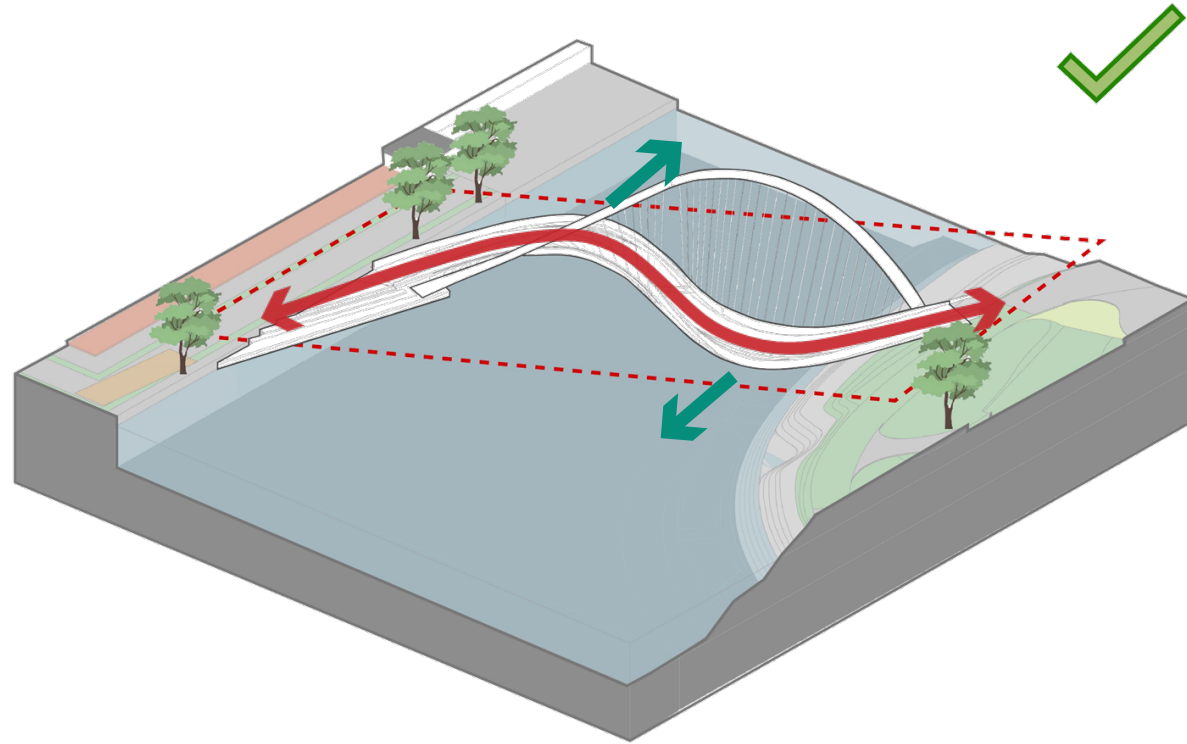

S-Deck and Arch

- + No barriers at Quayside promenade
- + Curving deck length resolves levels at Quayside
- + Natural traffic calming effect to allow pedestrians and cyclists to share bridge safely
- + Equal importance to each side of the bridge, creating a balanced approach and views to both sides
- + Informed by directionality and a connection to place
- + Arch is structurally efficient and requires minimal steel
- + Ties in with the 'family of bridges' approach in elevation, complimenting the Cherry Street North bridges
- + Form aligns with sinuous forms of the deck and natural landscape

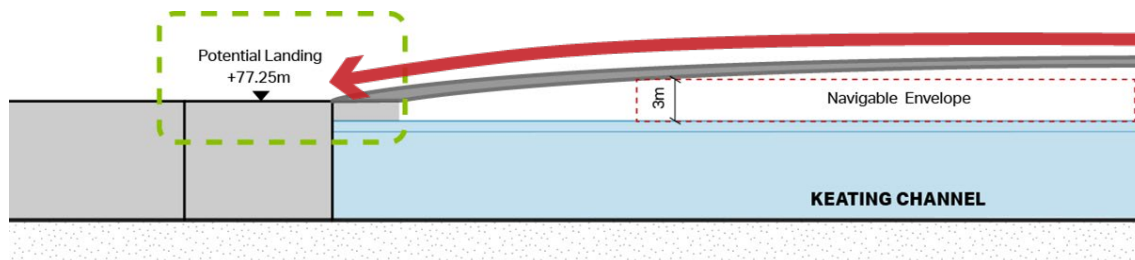

Concept Design Studies



Bridge Deck Geometry and Anti-funicular Arch selected for development in final design

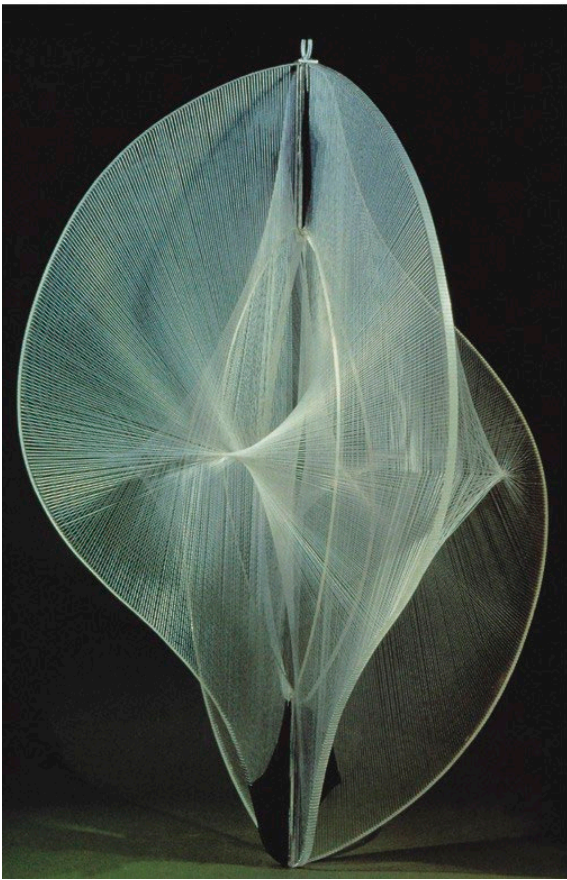

Naum Gabo - Cable Sculptures



Final Concept Design



S-shaped bridge aligns with north quay and park finished levels. All ramping is part of bridge geometry

Concept Plan

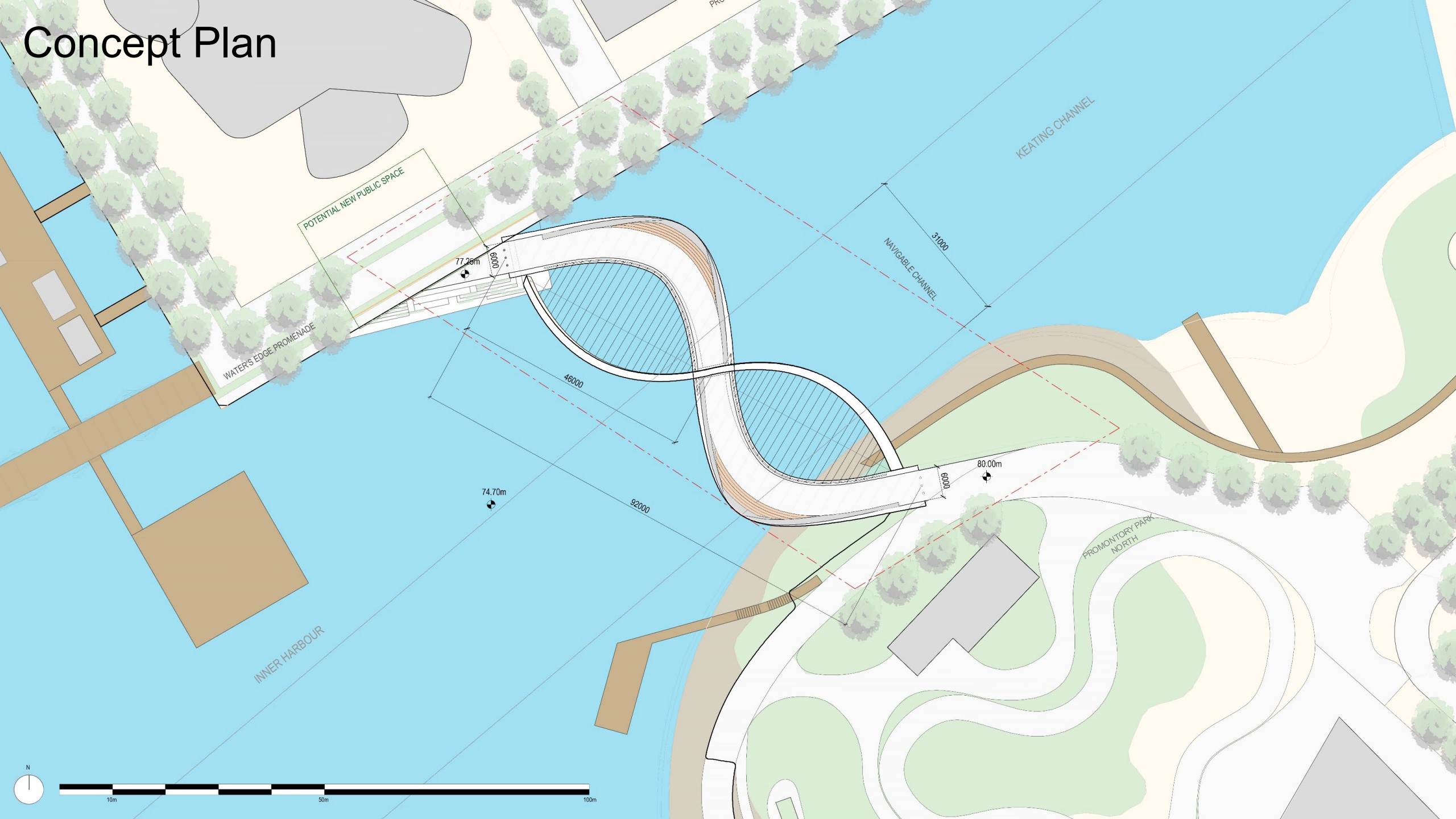

Concept Plan

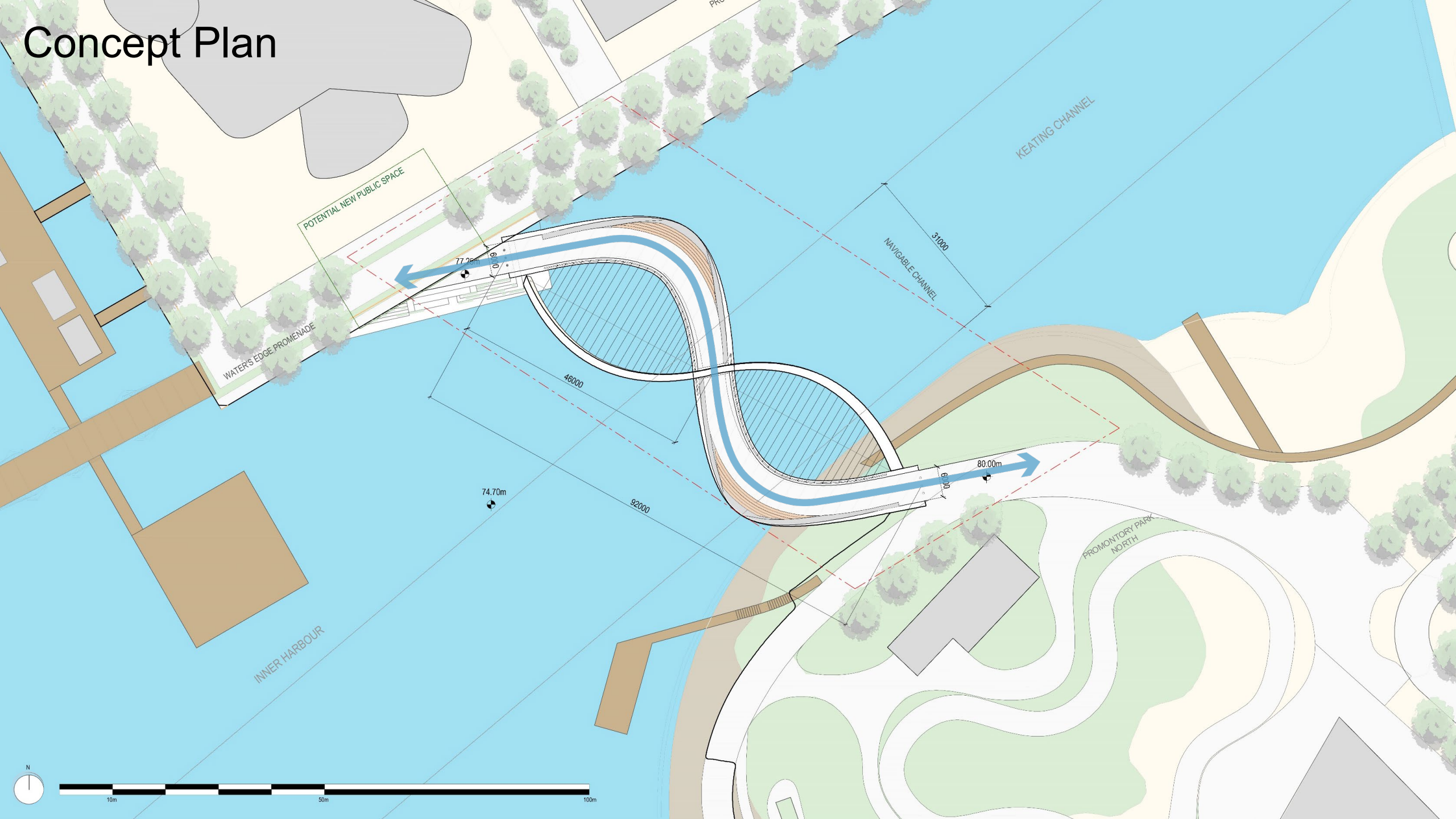



Aerial view from North Quay

Final Concept Design



Sinuous bridge deck with integrated perforated wind screens



Inclusive spaces for all to enjoy- timber seating accessed via perimeter ramp and steps



Noses to the deck provide seating and connection to the water

Materiality and Sustainability

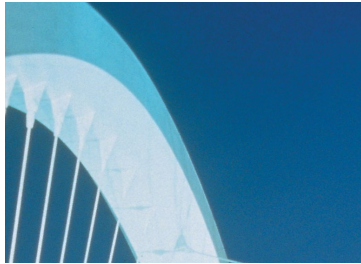

A – Painted Steel



B – Stainless Steel

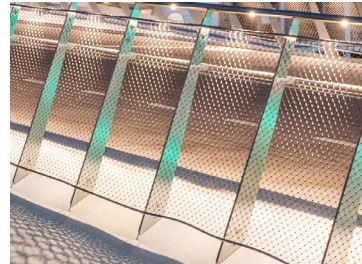

C – Wire Mesh & Brushed Steel

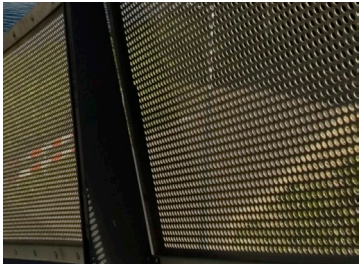

D – Perforated Metal

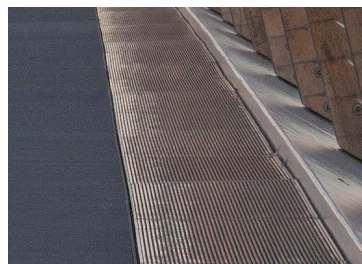

E – Wedge Wire



F – Timber Slats

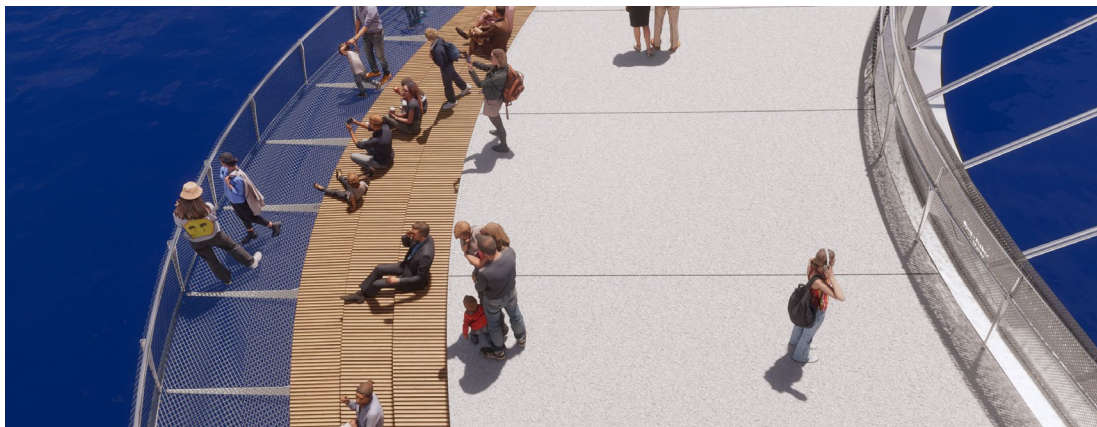

Accessible stepped seating areas for views out to the water



Sectional cut through bridge to indicate conceptual construction and materiality

- Highly efficient arch design reducing steel tonnage and carbon intensity
- Landscaping strategy to align with indigenous planting and include rainwater filtration
- Locally sourced materials
- Low maintenance and high durability of chosen materials



Dusk View of Keating Bridge from South

Longitudinal Section

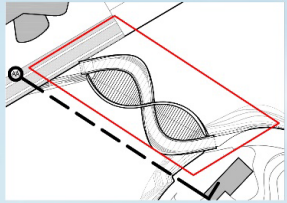

Key Plan

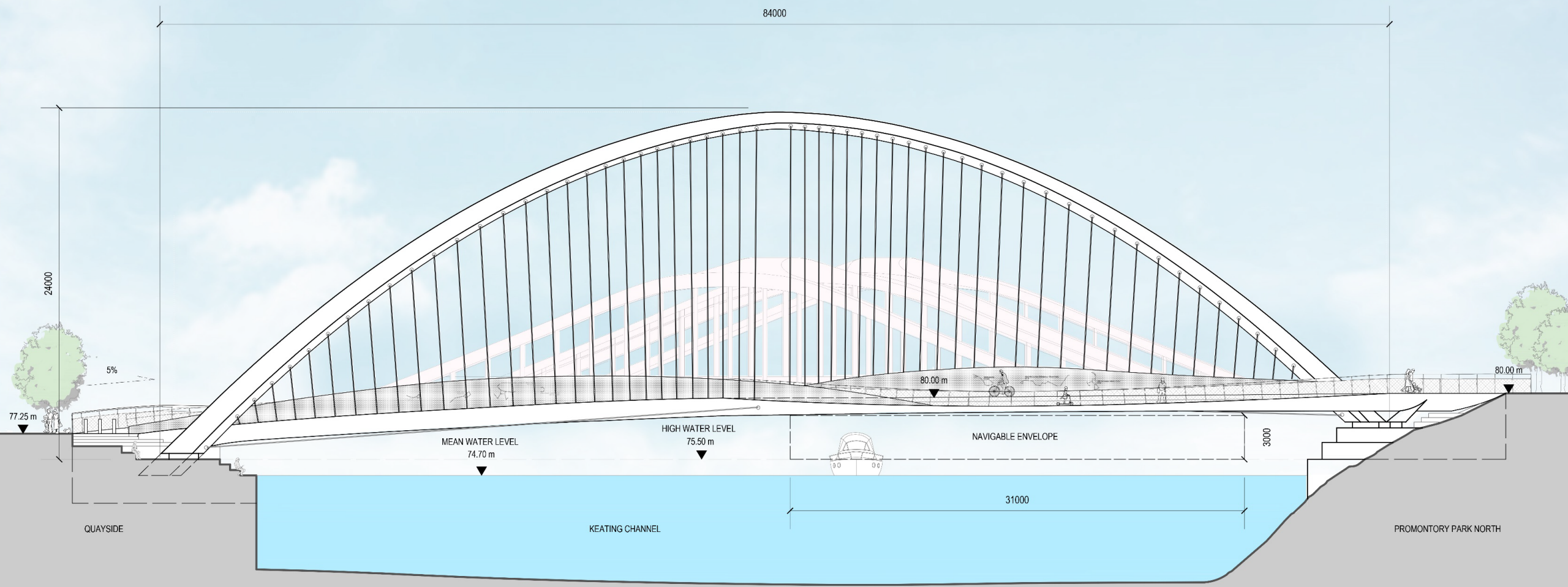

Indigenous Design Approach

- Design informed by directionality, through connection to the cardinal directions, and to the sky, water, and land
- A form that connects to the summer solstice and winter solstice days.
- Inclusion of native plantings that contribute to soil remediation, water filtration, and the health of the ecosystem
- Connection and acknowledgement to the sacredness of water
- Seating areas that encourage gathering and connection, to each other as well as to All Our Relations
- Work that is done is a good way, driven by consultation with local knowledge keepers and Elders, to listen and learn appropriate way to reflect the unique perspectives, stories, and wisdom of the MCFN in a respectful and contemporary way.



Final Concept Design



a Summer Solstice sunrise from the north-east viewing point

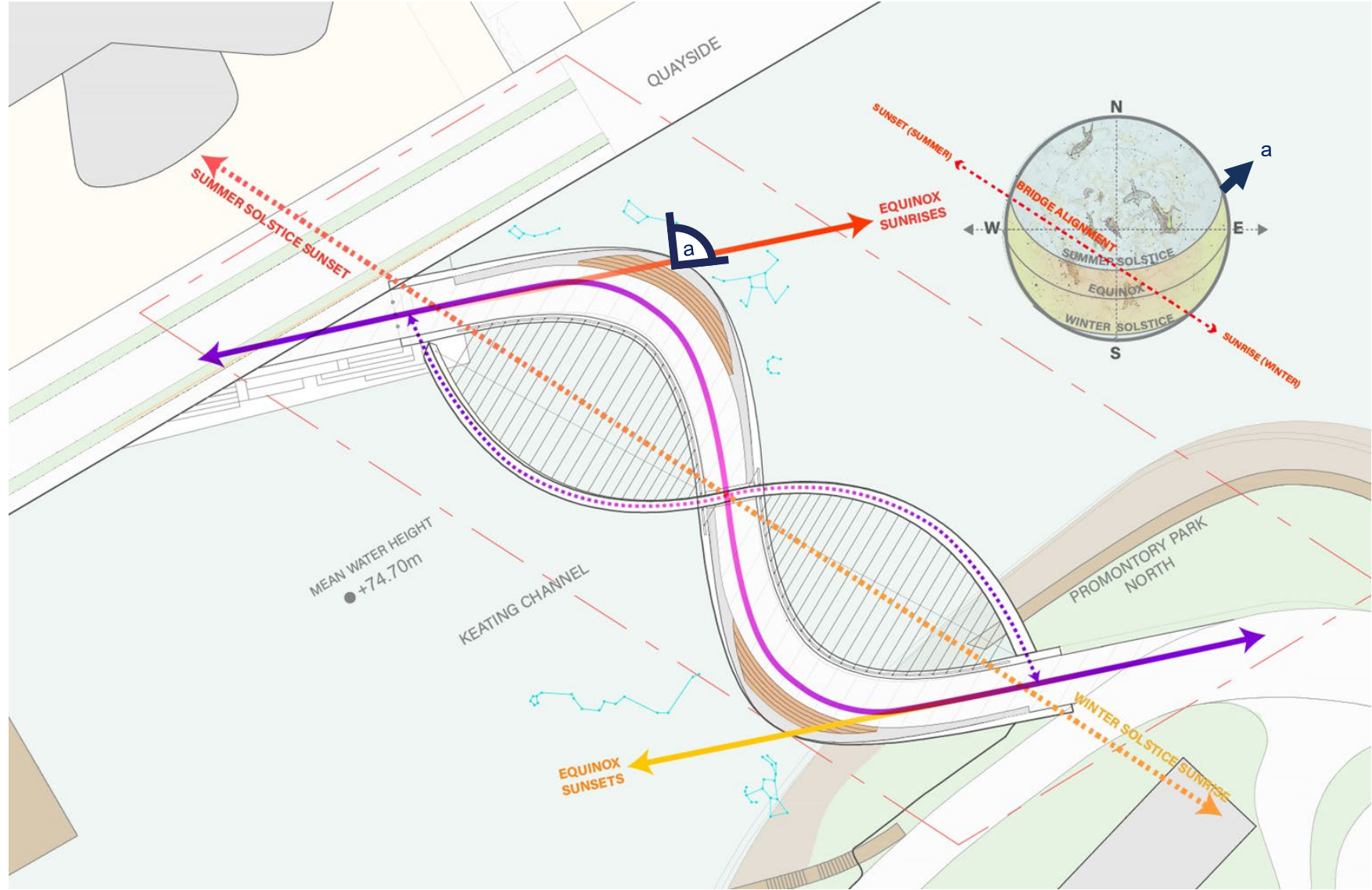

Final Concept Design



a
Summer Solstice sunrise from the north-east viewing point



b
Winter Solstice sunset from the south-west viewing point

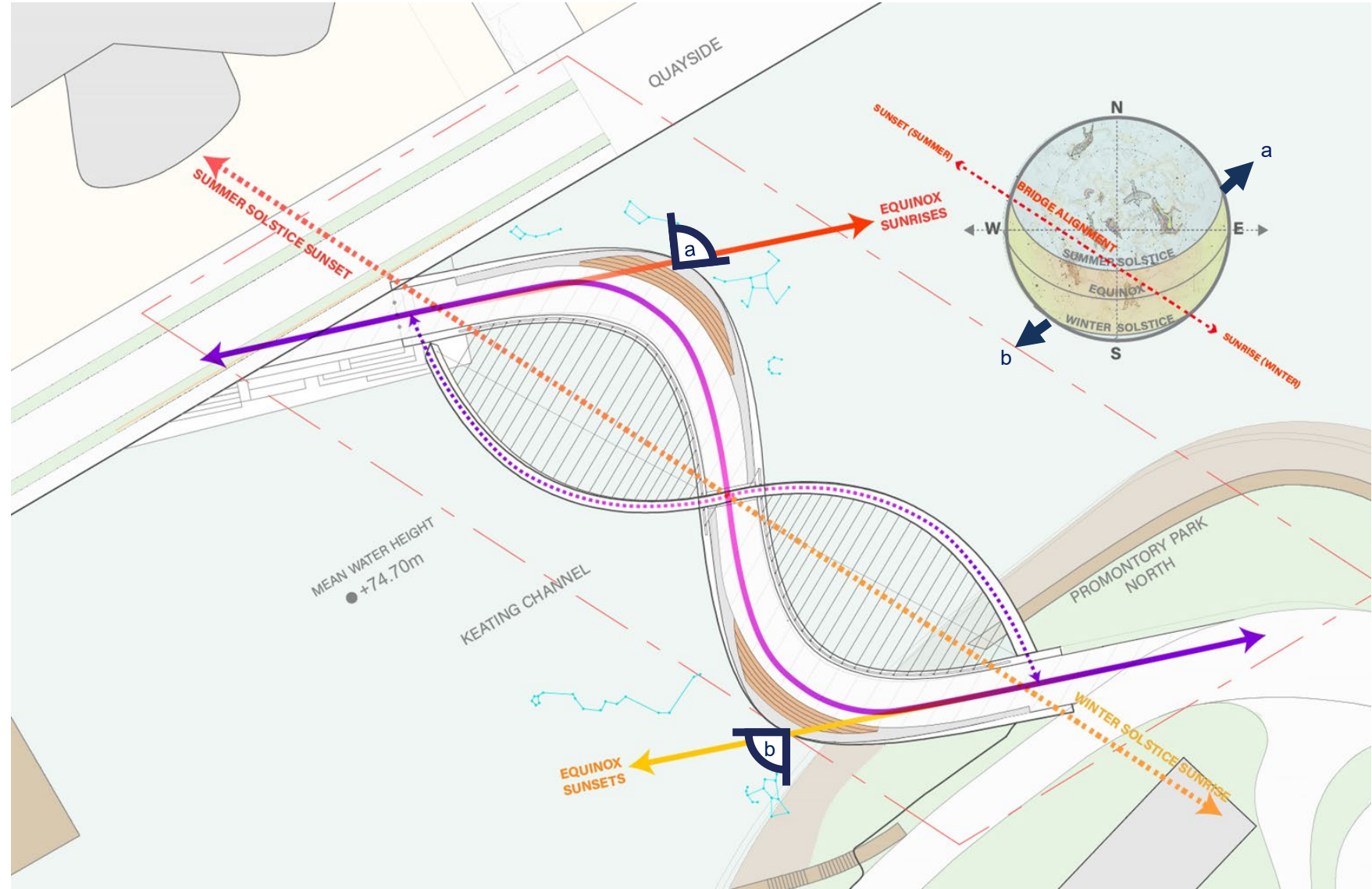

Final Concept Design



a Summer Solstice sunrise from the north-east viewing point



b Winter Solstice sunset from the south-west viewing point

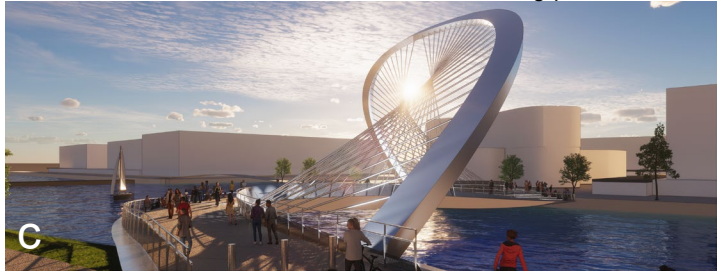

c Summer Solstice sunset through the arch

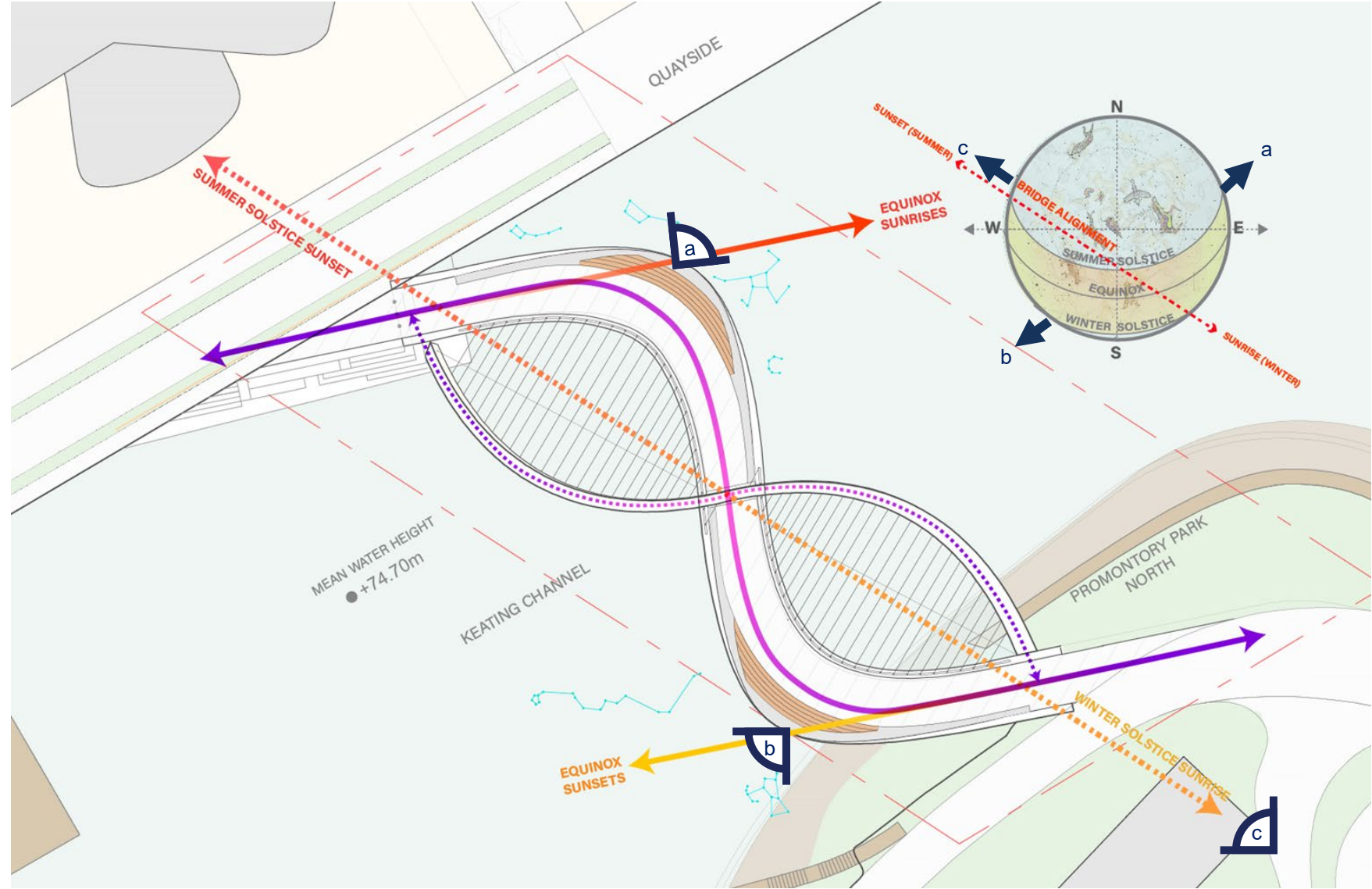

Final Concept Design



a Summer Solstice sunrise from the north-east viewing point

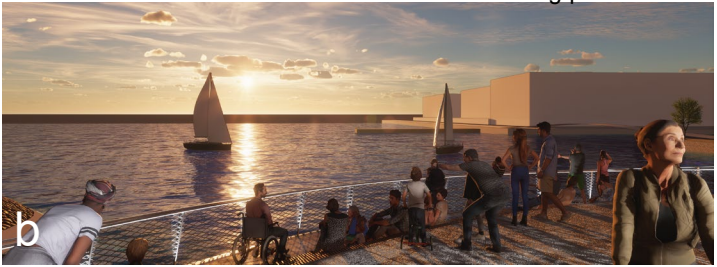

b Winter Solstice sunset from the south-west viewing point

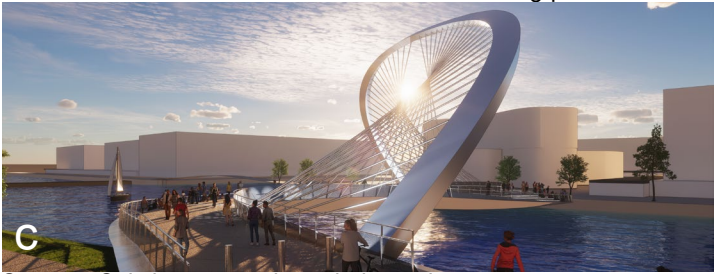

c Summer Solstice sunset through the arch



d Winter Solstice sunrise through the arch

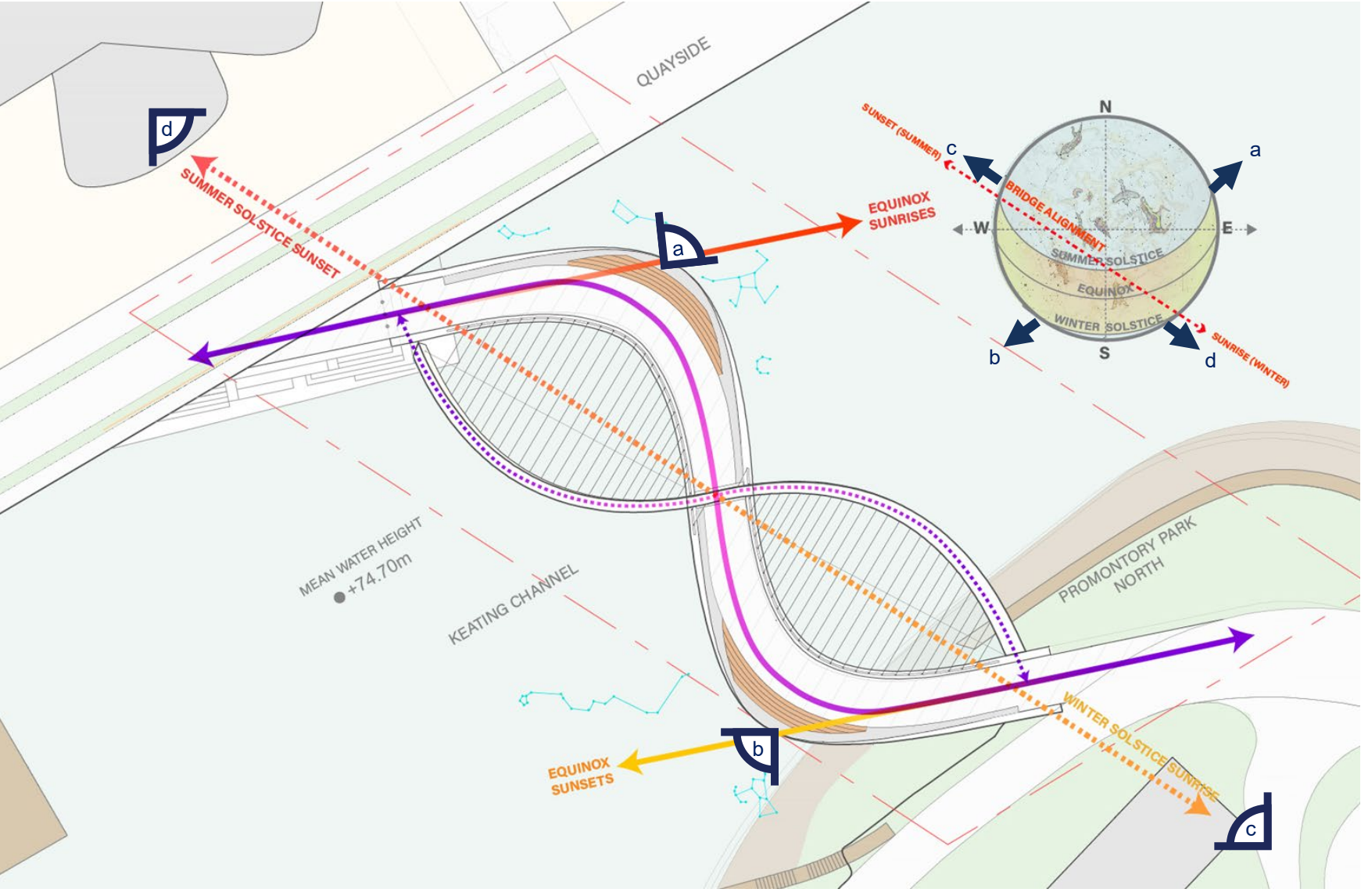

Lighting Design



Constellations are projected across the deck, glistening in the sunset

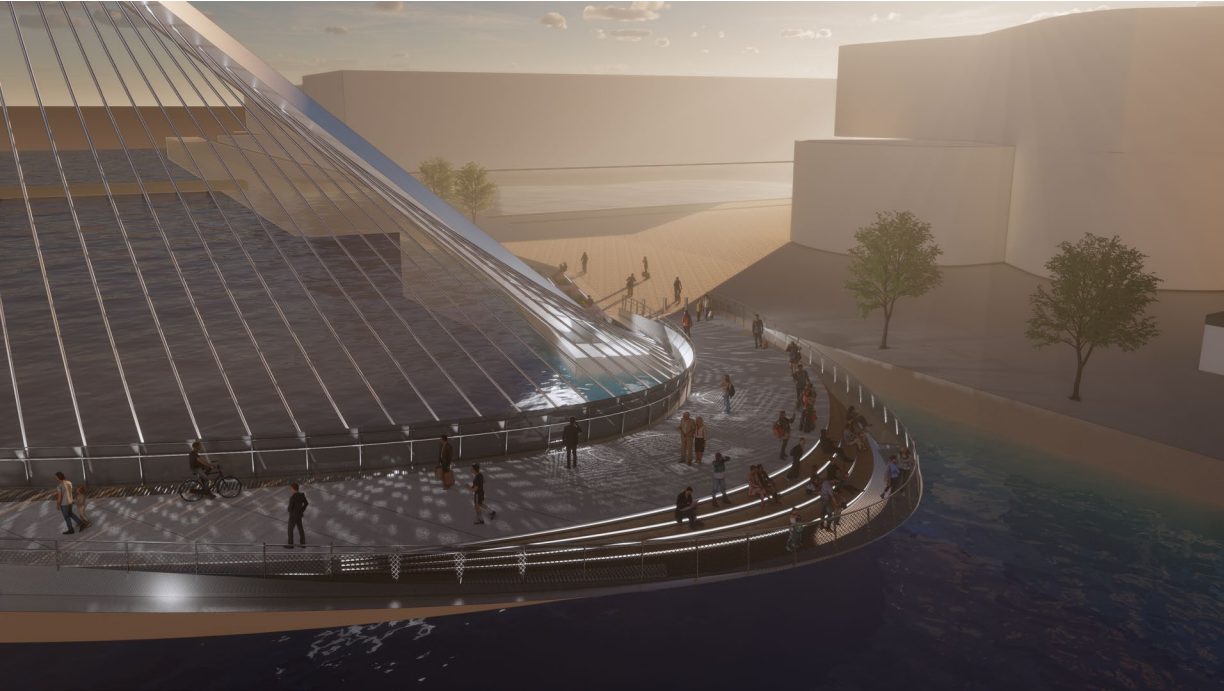

Light dances in the water reflected from the bridge

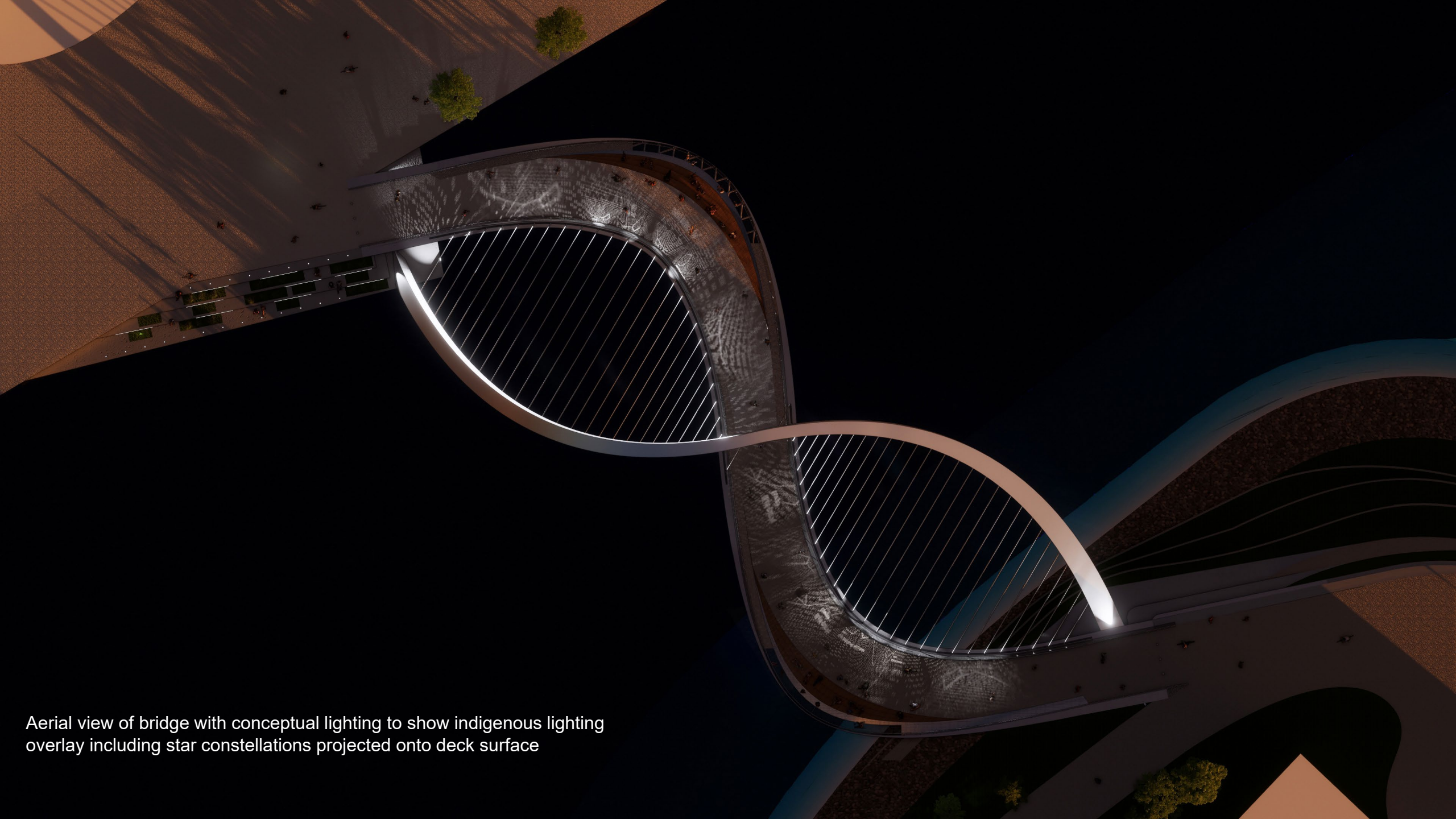

Aerial view of bridge with conceptual lighting to show indigenous lighting overlay including star constellations projected onto deck surface



Night View of Keating Bridge from South
with Feature Lighting Concept

Landscape Design

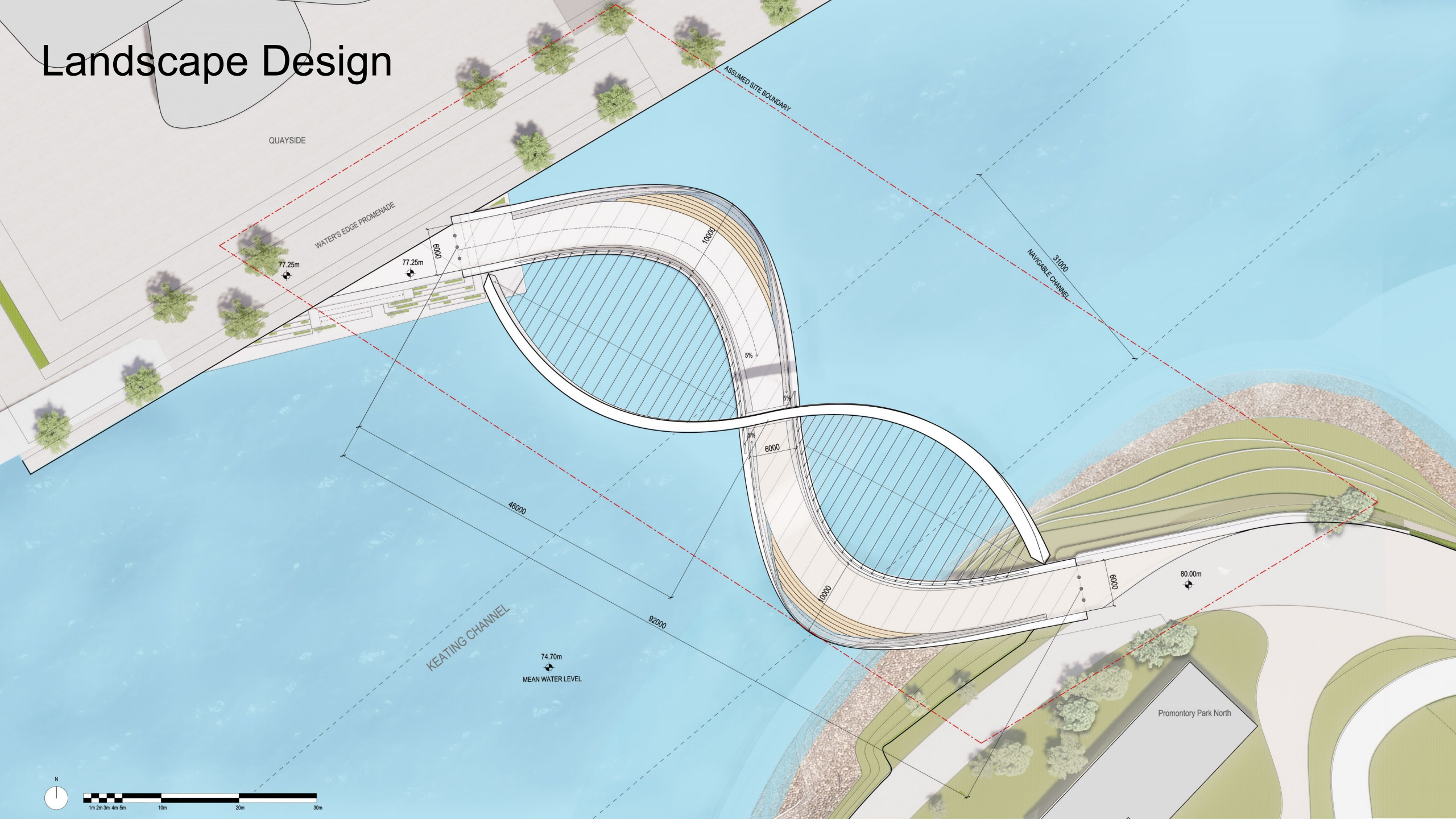

QUAYSIDE

WATER'S EDGE PROMENADE

77.25m

77.25m

6000

10000

5%

5%

8%

6000

10000

6000

80.00m

46000

92000

KEATING CHANNEL

74.70m
MEAN WATER LEVEL

NAVIGABLE CHANNEL
31000

Promontory Park North

N



Landscape Design

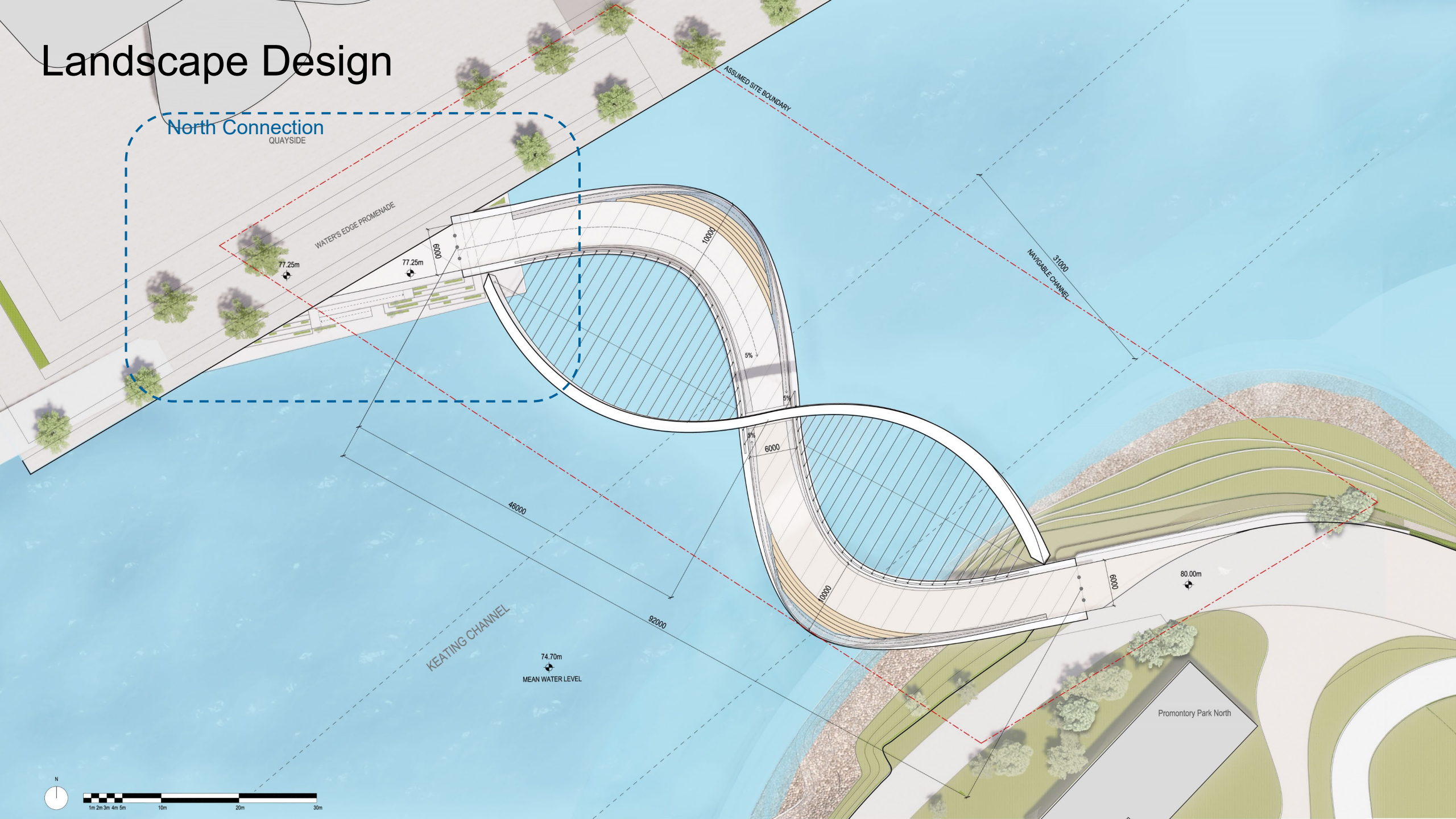

North Connection
QUAYSIDE

WATER'S EDGE PROMENADE

77.25m

77.25m

8000

10000

5%

5%

8%

6000

10000

8000

80.00m

NAVIGABLE CHANNEL
31000

KEATING CHANNEL
46000
92000

74.70m
MEAN WATER LEVEL

Promontory Park North



Landscape Design – North Connection



Stepped Seating | Nathan Philipps Square - PLANT Architect Inc.



Water Feature + Bench | Gallery of Freedom Square - 501 Architects

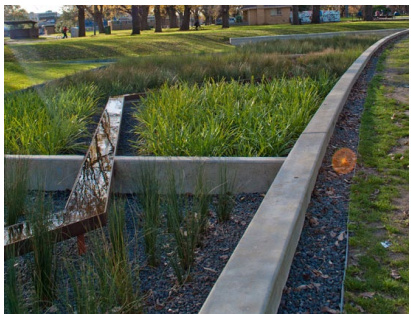

Raingarden Plantings | Edinburgh Gardens Raingarden - GHD Pty Ltd

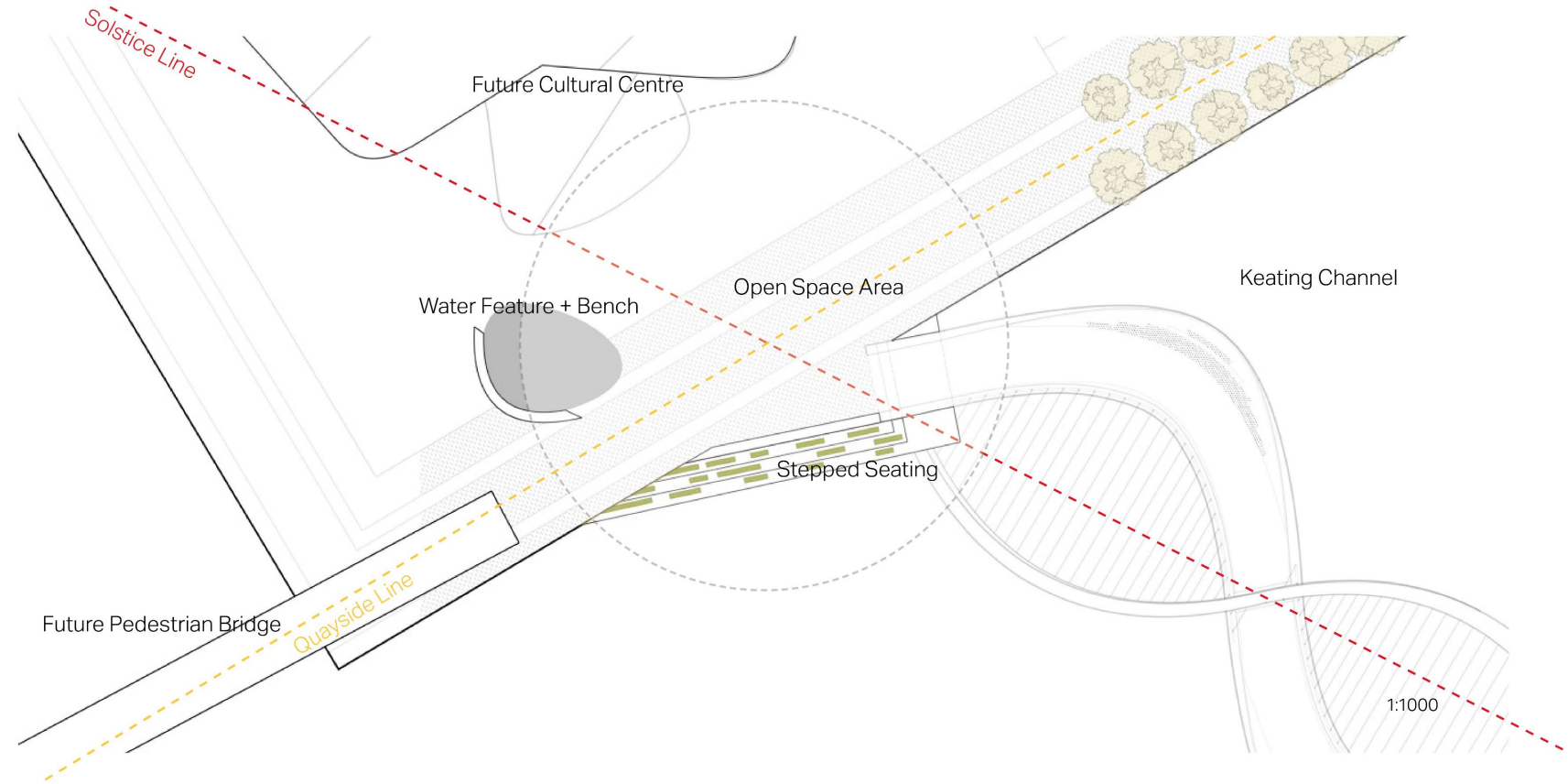

Landscape Design

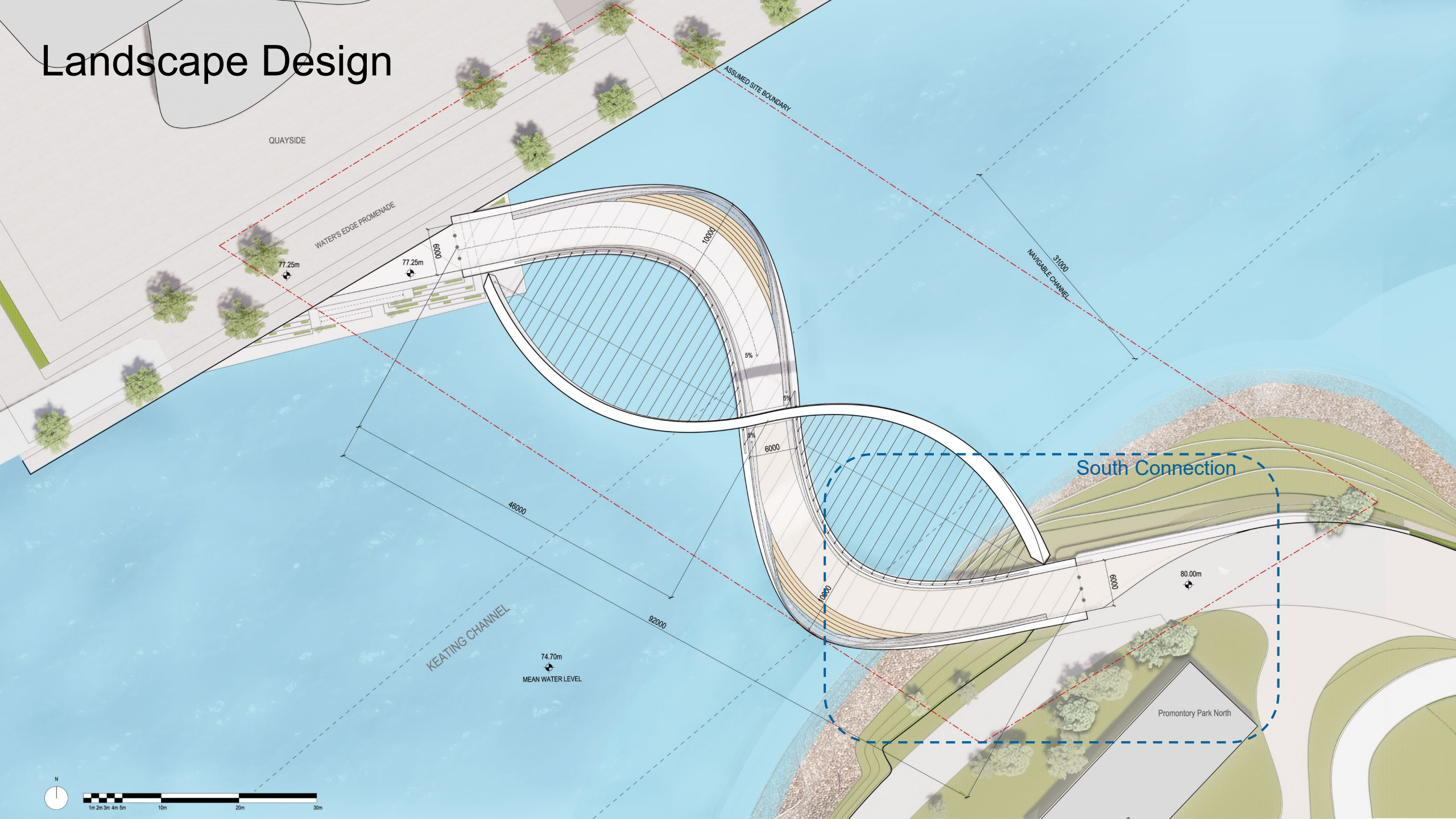

QUAYSIDE

WATER'S EDGE PROMENADE

77.25m

77.25m

6000

ASSUMED SITE BOUNDARY

10000

5%

5%

5%

6000

6000

80.00m

46000

92000

KEATING CHANNEL

74.70m
MEAN WATER LEVEL

South Connection

NAVIGABLE CHANNEL
31000

Promontory Park North

N



Landscape Design – South Connection



Woodland Plantings & Planted Areas | Dorpsweide - Atelier Loos van Vliet



Sloped Lawn & Seat Wall | Buckingham Browne and Nichols - Stephen Stimson Associates



Stepped Seating | Calgary Bow RiverWalk - Stantec / Moriyama Teshima Planners

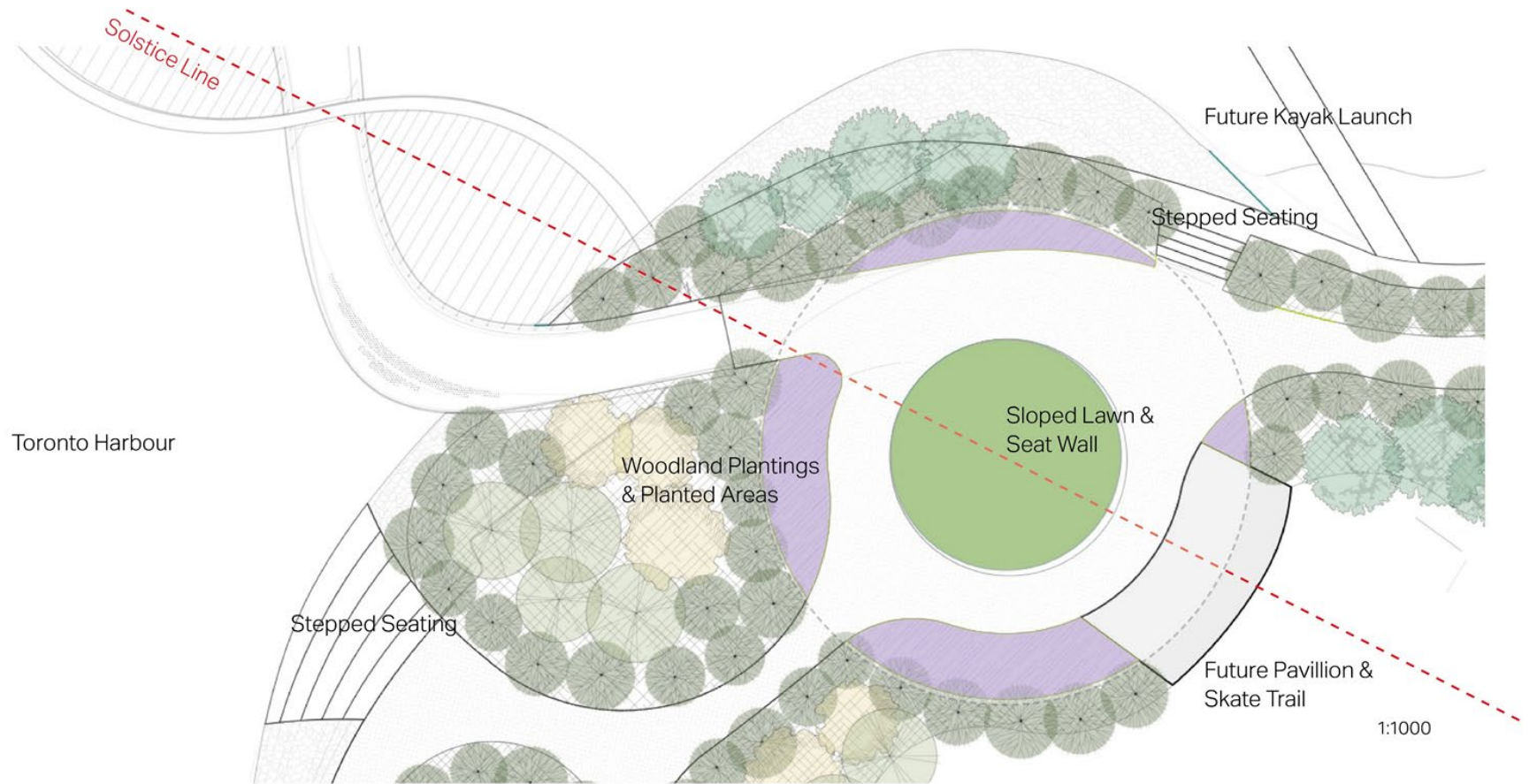

Structural Engineering

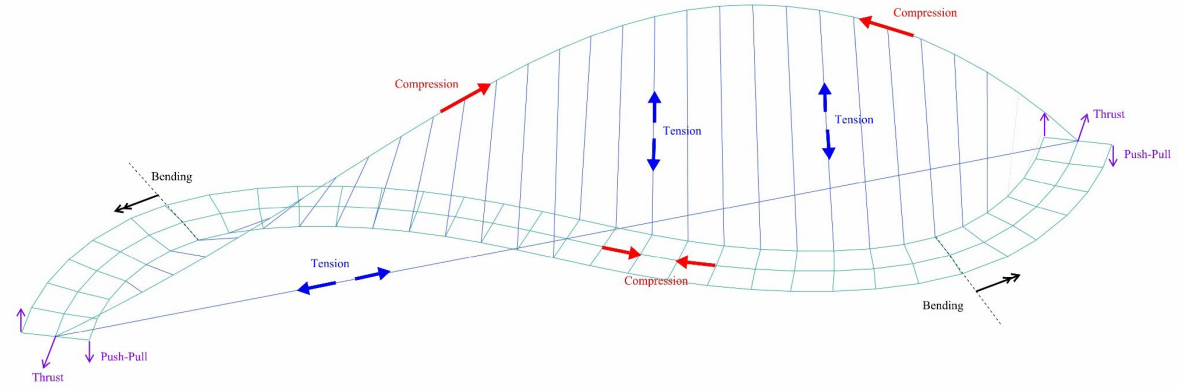
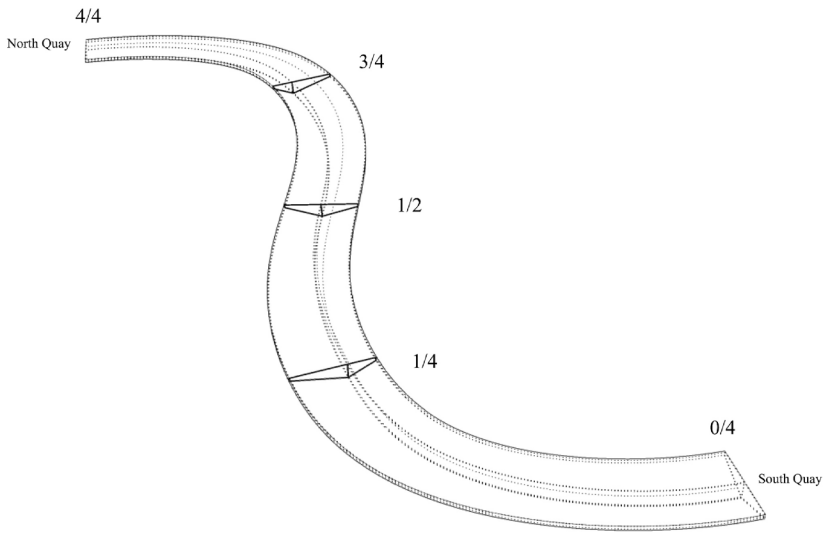

Load path diagram of the funicular arch and the deck

Modal shapes of the bridge

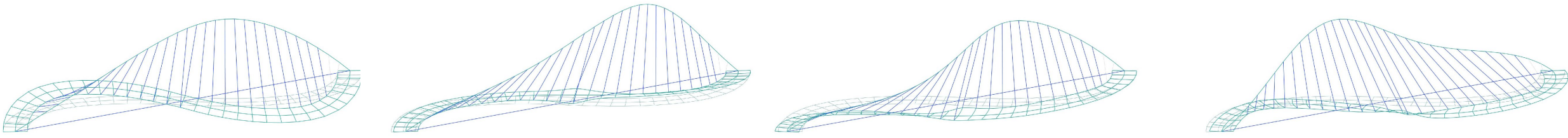

Structural Engineering

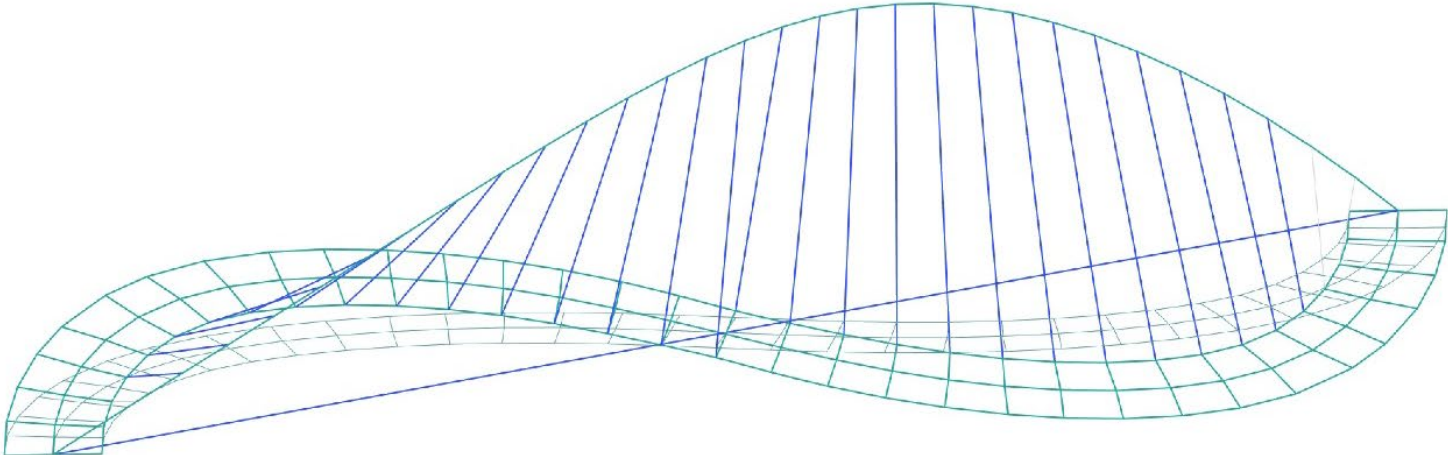

Structural Engineering

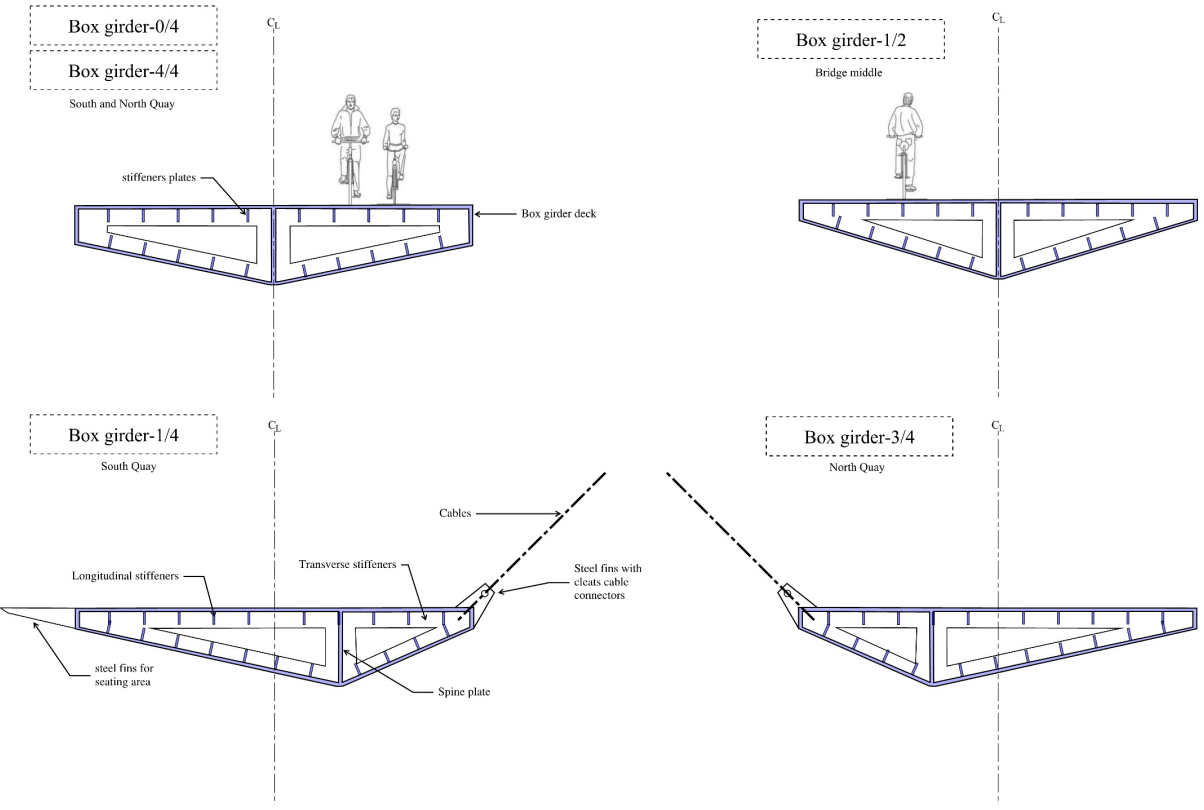
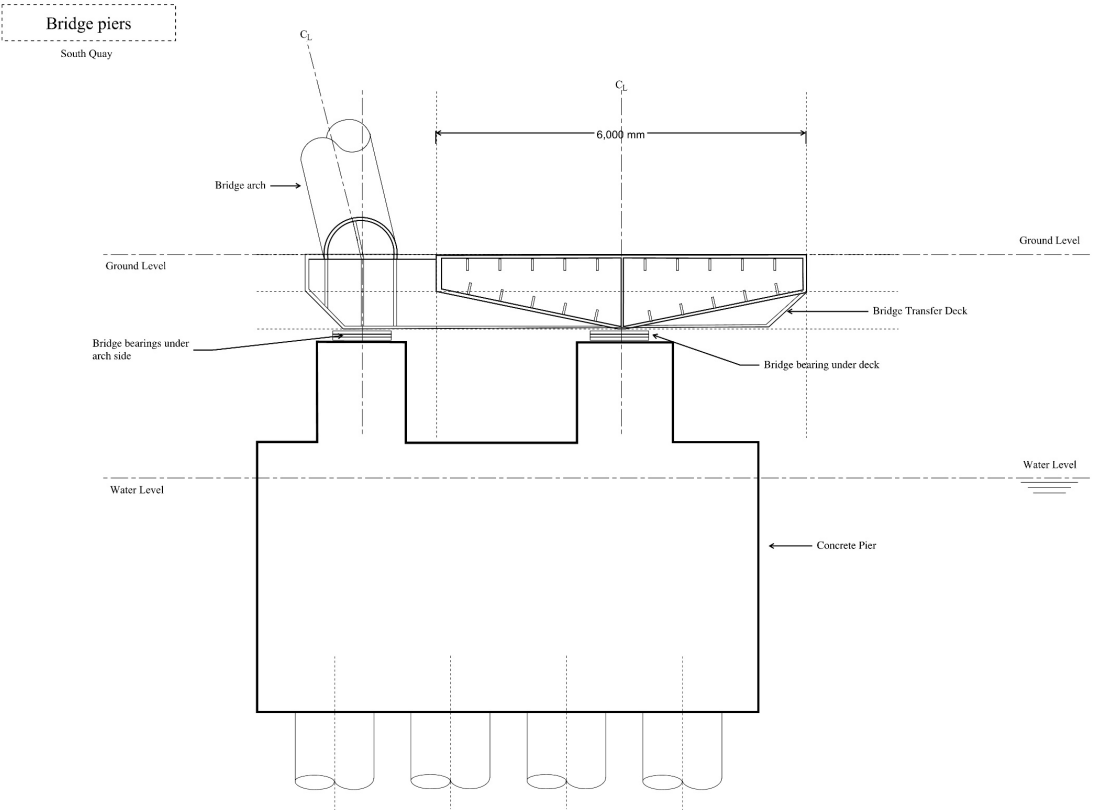

Transverse Section

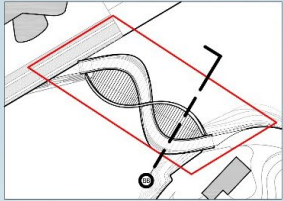

Key Plan

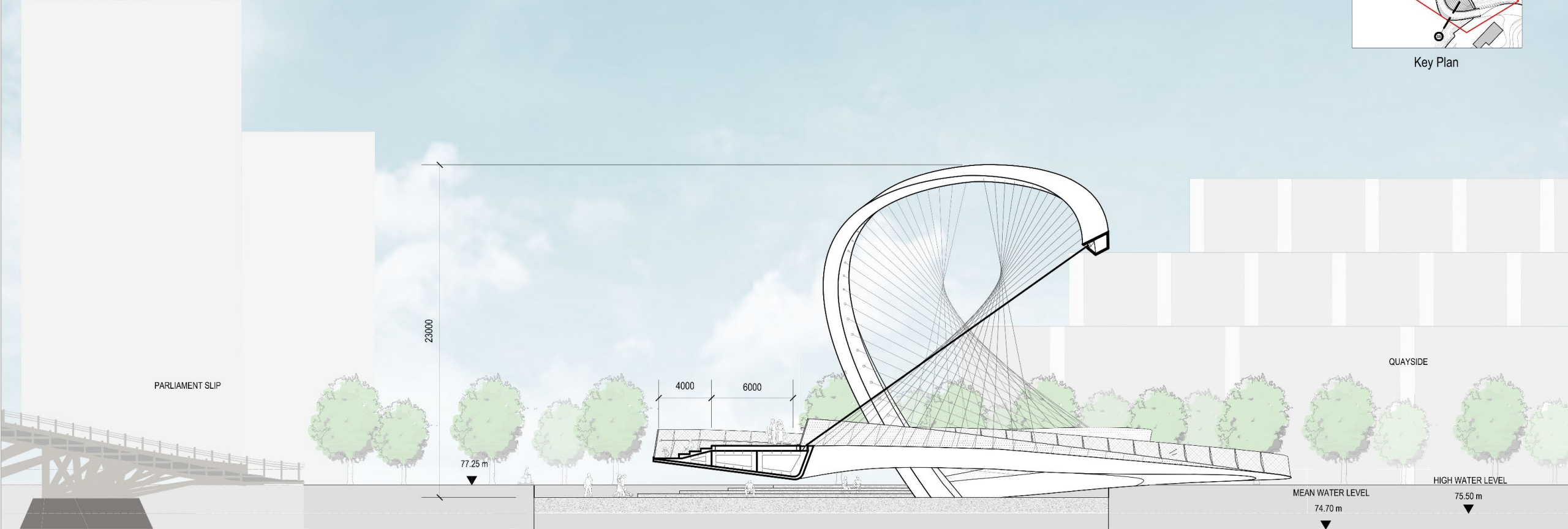

KEATING CHANNEL





Proposed bridge from west with view down Keating Channel, complimenting the family of bridges